

## 省空间

直交型减速机使用螺旋式伞齿轮，马达的安装可实现90度弯曲，节省了安装空间

## Space - saving

Right angle reducer using spiral bevel gear. Customer can locate the motor at 90 degree away from the reducer if required to save space.

## 高刚性，高扭矩

使用整体式滚珠轴承，大大提高刚性和扭矩

## High rigidity & torque

High rigidity & high torque were achieved by uncaged needle roller bearings.

## 法兰、轴套方式

可以安装到任何一台马达上

## Adapter-bushing connection

Can be attached to any motor all over the world.

## 无润滑油脂泄漏

使用高粘度、不易分离的润滑脂，有效防止润滑脂泄漏

## No grease leakage

Perfect solving using high viscosity anti-separation grease.

## 维护方便

在产品寿命期内无需更换润滑脂，安装更便捷

## Maintenance-free

No need to replace the grease for the life of the unit. Can be attached in any position.

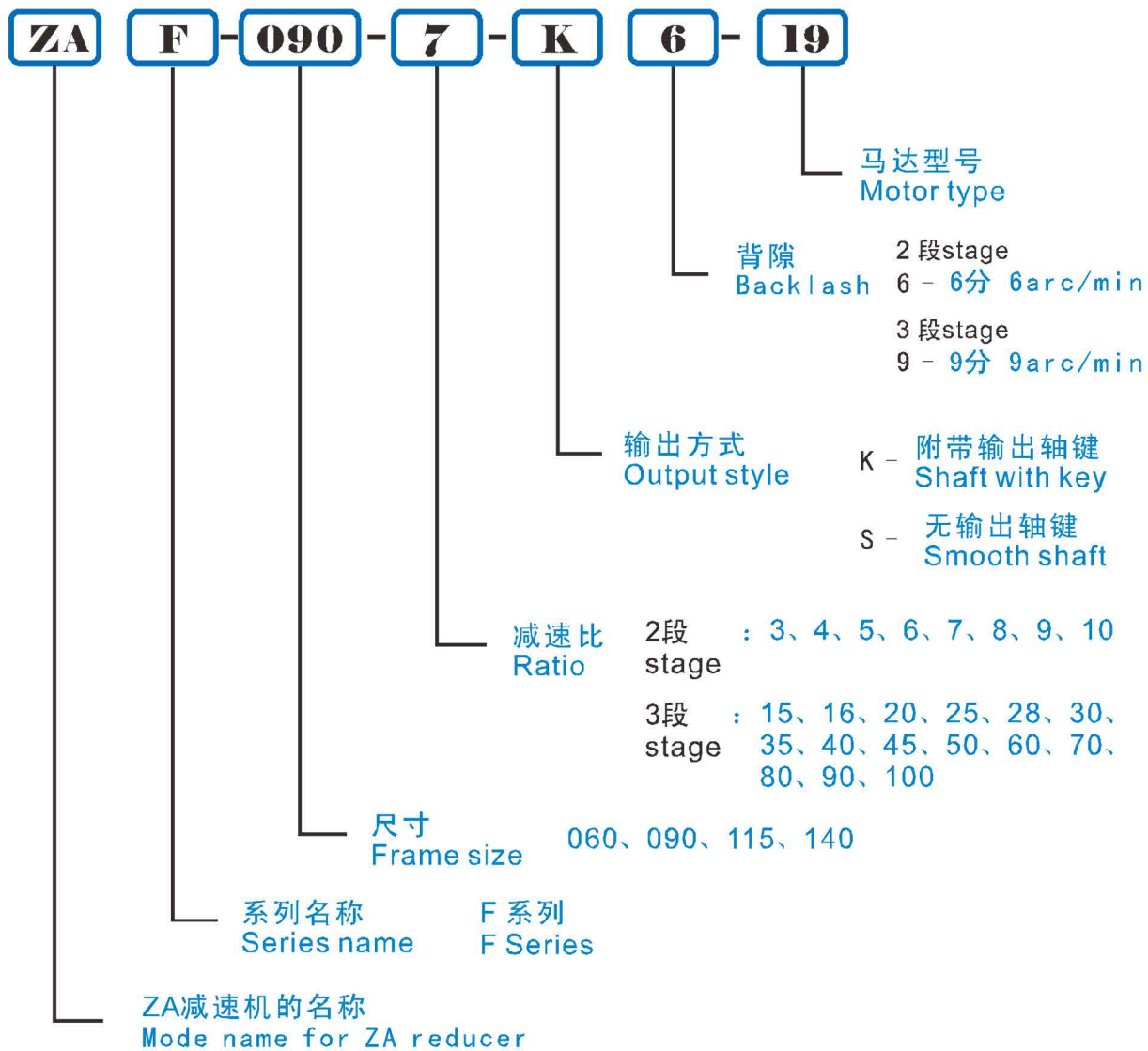

如有不明白之处，欢迎咨询。

Please contact us for more information.



## ZAF-060

尺寸 Frame size	段位 Stage	减速比 Ratio	容许额定扭矩 Nominal output torque [Nm]	容许最大扭矩 Maximum output torque [Nm]	紧急最大扭矩 Emergency stop torque [Nm]	容许额定输入转速 Nominal input speed [rpm]	容许最高输入转速 Maximum input speed [rpm]	容许径向负荷 Permitted radial load [N]	容许轴向负荷 Permitted axial load [N]	
060	2段 Stage	3	12	24	50	3000	6000	430	310	
		4	16	32	65	3000	6000	470	360	
		5	22	40	80	3000	6000	510	390	
		6	24	45	90	3000	6000	540	430	
		7	24	45	90	3000	6000	570	460	
		8	24	45	90	3000	6000	600	480	
		9	16	32	65	3000	6000	620	510	
		10	16	32	65	3000	6000	640	530	
		3段 Stage	15	16	32	65	3000	6000	740	630
			16	24	45	90	3000	6000	750	650
	20		24	45	90	3000	6000	810	720	
	25		24	45	90	3000	6000	870	790	
	28		24	45	90	3000	6000	910	830	
	30		16	32	65	3000	6000	930	860	
	35		24	45	90	3000	6000	980	920	
	40		24	45	90	3000	6000	1000	970	
	45		16	32	65	3000	6000	1100	1000	
	50		24	45	90	3000	6000	1100	1100	
	60	24	45	90	3000	6000	1200	1100		
	70	24	45	90	3000	6000	1200	1100		
80	24	45	90	3000	6000	1200	1100			
90	16	32	65	3000	6000	1200	1100			
100	16	32	65	3000	6000	1200	1100			

尺寸 Frame size	段位 Stage	减速比 Ratio	容许最大径向负荷 Maximum radial load [N]	容许最大轴向负荷 Maximum axial load [N]	重量 Weight [kg]	惯性力矩 Moment of inertia (<math>\leq \Phi 8</math>) [kgcm <sup>2</sup> ]	惯性力矩 Moment of inertia (<math>\leq \Phi 14</math>) [kgcm <sup>2</sup> ]	惯性力矩 Moment of inertia (<math>\leq \Phi 19</math>) [kgcm <sup>2</sup> ]		
060	2段 Stage	3	1200	1100	1.8	0.31	0.39	0.58		
		4	1200	1100		0.27	0.34	0.53		
		5	1200	1100		0.25	0.32	0.51		
		6	1200	1100		0.24	0.31	0.50		
		7	1200	1100		0.23	0.31	0.50		
		8	1200	1100		0.23	0.31	0.50		
		9	1200	1100		0.23	0.30	0.49		
		10	1200	1100		0.23	0.30	0.49		
		3段 Stage	15	1200		1100	1.6	0.073	0.118	-
			16	1200		1100		0.079	0.124	-
	20		1200	1100	0.071	0.116		-		
	25		1200	1100	0.071	0.115		-		
	28		1200	1100	0.077	0.122		-		
	30		1200	1100	0.062	0.106		-		
	35		1200	1100	0.070	0.115		-		
	40		1200	1100	0.061	0.106		-		
	45		1200	1100	0.070	0.115		-		
	50		1200	1100	0.061	0.106		-		
	60	1200	1100	0.061	0.106	-				
	70	1200	1100	0.061	0.105	-				
80	1200	1100	0.061	0.105	-					
90	1200	1100	0.061	0.105	-					
100	1200	1100	0.061	0.105	-					

- ※ 1 输入转速为额定转速时,使用寿命为20000小时的值
- ※ 2 启动时、停止时容许最大值
- ※ 3 发生撞击时容许最大值(频率最高为1000次)
- ※ 4 运转过程中,额定输入转速容许最大值
- ※ 5 在非连续运转条件下容许最高输入转速
- ※ 6 输入转速为额定转速时,使用寿命为20000个小时的值(作用于轴中央,轴向负荷为0时)
- ※ 7 输入转速为额定转速时,使用寿命为20000个小时的值(作用于轴芯,径向负荷为0时)
- ※ 8 径向负荷容许最大值
- ※ 9 轴向负荷容许最大值
- ※ 10 因减速比和输入轴尺寸的不同而有所不同。

- ※ 1 With nominal input speed, service life is 20,000 hours
- ※ 2 The maximum torque when starting and stopping
- ※ 3 The maximum torque when it receives shock (up to 1000times)
- ※ 4 The maximum average input speed.
- ※ 5 The maximum momentary input speed.
- ※ 6 With this load and nominal input speed, service life will be 20,000 hours (Applied to the output shaft center, at axial load 0)
- ※ 7 With this load and nominal input speed, service life will be 20,000 hours (Applied to the output side bearing, at radial load 0)
- ※ 8 The maximum radial load the reducer can accept
- ※ 9 The maximum axial load the reducer can accept
- ※ 10 The weight may vary slightly model to model.

## ZAF-090

尺寸 Frame size	段位 Stage	减速比 Ratio	容许额定扭矩 Nominal output torque [Nm]	容许最大扭矩 Maximum output torque [Nm]	紧急最大扭矩 Emergency stop torque [Nm]	容许额定输入转速 Nominal input speed [rpm]	容许最高输入转速 Maximum input speed [rpm]	容许径向负荷 Permitted radial load [N]	容许轴向负荷 Permitted axial load [N]	
090	2段 Stage	3	45	65	130	3000	6000	810	930	
		4	60	90	170	3000	6000	890	1100	
		5	65	90	220	3000	6000	960	1200	
		6	65	90	220	3000	6000	1000	1300	
		7	65	90	220	3000	6000	1100	1300	
		8	65	90	220	3000	6000	1100	1400	
		9	45	65	170	3000	6000	1200	1500	
		10	45	65	170	3000	6000	1200	1600	
		3段 Stage	15	45	65	170	3000	6000	1400	1900
			16	65	110	220	3000	6000	1400	1900
	20		65	110	220	3000	6000	1500	2100	
	25		65	110	220	3000	6000	1600	2200	
	28		65	110	220	3000	6000	1700	2200	
	30		45	65	170	3000	6000	1700	2200	
	35		65	110	220	3000	6000	1800	2200	
	40		65	110	220	3000	6000	1900	2200	
	45		45	65	170	3000	6000	2000	2200	
	50		65	110	220	3000	6000	2100	2200	
	60	65	110	220	3000	6000	2200	2200		
	70	65	110	220	3000	6000	2300	2200		
80	65	110	220	3000	6000	2400	2200			
90	45	65	170	3000	6000	2400	2200			
100	45	65	170	3000	6000	2400	2200			

尺寸 Frame size	段位 Stage	减速比 Ratio	容许最大径向负荷 Maximum radial load [N]	容许最大轴向负荷 Maximum axial load [N]	重量 Weight [kg]	惯性力矩 Moment of inertia (<math>\leq \Phi 8</math>) [kgcm <sup>2</sup> ]	惯性力矩 Moment of inertia (<math>\leq \Phi 14</math>) [kgcm <sup>2</sup> ]	惯性力矩 Moment of inertia (<math>\leq \Phi 19</math>) [kgcm <sup>2</sup> ]	惯性力矩 Moment of inertia (<math>\leq \Phi 19</math>) [kgcm <sup>2</sup> ]		
090	2段 Stage	3	2400	2200	5.1	-	2.12	2.45	4.57		
		4	2400	2200		-	1.89	2.22	4.35		
		5	2400	2200		-	1.80	2.13	4.26		
		6	2400	2200		-	1.76	2.09	4.21		
		7	2400	2200		-	1.73	2.06	4.18		
		8	2400	2200		-	1.71	2.04	4.17		
		9	2400	2200		-	1.70	2.03	4.16		
		10	2400	2200		-	1.69	2.02	4.15		
		3段 Stage	15	2400		2200	4.4	0.34	0.41	0.60	-
			16	2400		2200		0.38	0.46	0.65	-
	20		2400	2200	0.33	0.40		0.59	-		
	25		2400	2200	0.32	0.40		0.59	-		
	28		2400	2200	0.37	0.45		0.64	-		
	30		2400	2200	0.25	0.33		0.51	-		
	35		2400	2200	0.25	0.40		0.59	-		
	40		2400	2200	0.32	0.32		0.51	-		
	45		2400	2200	0.25	0.39		0.58	-		
	50		2400	2200	0.25	0.32		0.51	-		
	60	2400	2200	0.25	0.32	0.51	-				
	70	2400	2200	0.25	0.32	0.51	-				
80	2400	2200	0.25	0.32	0.51	-					
90	2400	2200	0.25	0.32	0.51	-					
100	2400	2200	0.25	0.32	0.51	-					

- ※ 1 输入转速为额定转速时,使用寿命为20000小时的值
- ※ 2 启动时、停止时容许最大值
- ※ 3 发生撞击时容许最大值(频率最高为1000次)
- ※ 4 运转过程中,额定输入转速容许最大值
- ※ 5 在非连续运转条件下容许最高输入转速
- ※ 6 输入转速为额定转速时,使用寿命为20000个小时的值(作用于轴中央,轴向负荷为0时)
- ※ 7 输入转速为额定转速时,使用寿命为20000个小时的值(作用于轴芯,径向负荷为0时)
- ※ 8 径向负荷容许最大值
- ※ 9 轴向负荷容许最大值
- ※ 10 因减速比和输入轴尺寸的不同而有所不同。

- ※ 1 With nominal input speed, service life is 20,000 hours
- ※ 2 The maximum torque when starting and stopping
- ※ 3 The maximum torque when it receives shock (up to 1000times)
- ※ 4 The maximum average input speed.
- ※ 5 The maximum momentary input speed.
- ※ 6 With this load and nominal input speed, service life will be 20,000 hours (Applied to the output shaft center, at axial load 0)
- ※ 7 With this load and nominal input speed, service life will be 20,000 hours (Applied to the output side bearing, at radial load 0)
- ※ 8 The maximum radial load the reducer can accept
- ※ 9 The maximum axial load the reducer can accept
- ※ 10 The weight may vary slightly model to model.



## ZAF-115

尺寸 Frame size	段位 Stage	减速比 Ratio	容许额定扭矩 Nominal output torque [Nm]	容许最大扭矩 Maximum output torque [Nm]	紧急最大扭矩 Emergency stop torque [Nm]	容许额定输入转速 Nominal input speed [rpm]	容许最高输入转速 Maximum input speed [rpm]	容许径向负荷 Permitted radial load [N]	容许轴向负荷 Permitted axial load [N]	
115	2段 Stage	3	75	150	320	3000	6000	1300	1500	
		4	100	200	430	3000	6000	1500	1700	
		5	120	240	500	3000	6000	1600	1900	
		6	150	300	550	3000	6000	1700	2000	
		7	150	300	550	3000	6000	1800	2100	
		8	150	300	550	3000	6000	1900	2300	
		9	110	200	450	3000	6000	1900	2400	
		10	110	200	450	3000	6000	2000	2500	
		3段 Stage	15	110	200	450	3000	6000	2300	3000
			16	130	260	550	3000	6000	2300	3100
	20		150	300	550	3000	6000	2500	3400	
	25		150	300	550	3000	6000	2700	3700	
	28		150	300	550	3000	6000	2800	3900	
	30		110	200	450	3000	6000	2900	3900	
	35		150	300	550	3000	6000	3000	3900	
	40		150	300	550	3000	6000	3200	3900	
	45		110	200	450	3000	6000	3300	3900	
	50		150	300	550	3000	6000	3400	3900	
	60	150	300	550	3000	6000	3600	3900		
	70	150	300	550	3000	6000	3800	3900		
80	150	300	550	3000	6000	4000	3900			
90	110	200	450	3000	6000	4200	3900			
100	110	200	450	3000	6000	4300	3900			

尺寸 Frame size	段位 Stage	减速比 Ratio	容许最大径向负荷 Maximum radial load [N]	容许最大轴向负荷 Maximum axial load [N]	重量 Weight [kg]	惯性力矩 (≤Φ14) [kgcm <sup>2</sup> ]	惯性力矩 (≤Φ19) [kgcm <sup>2</sup> ]	惯性力矩 (≤Φ28) [kgcm <sup>2</sup> ]	惯性力矩 (≤Φ38) [kgcm <sup>2</sup> ]		
115	2段 Stage	3	4300	3900	10.4	-	6.74	8.34	15.41		
		4	4300	3900		-	5.49	7.08	14.15		
		5	4300	3900		-	5.02	6.61	13.69		
		6	4300	3900		-	4.77	6.36	13.43		
		7	4300	3900		-	4.65	6.24	13.31		
		8	4300	3900		-	4.55	6.14	13.22		
		9	4300	3900		-	4.49	6.08	13.16		
		10	4300	3900		-	4.46	6.05	13.12		
		3段 Stage	15	4300		3900	10.1	2.25	2.58	4.70	-
			16	4300		3900		2.46	2.79	4.91	-
	20		4300	3900	2.20	2.53		4.65	-		
	25		4300	3900	2.18	2.51		4.64	-		
	28		4300	3900	2.40	2.73		4.86	-		
	30		4300	3900	1.87	2.20		4.33	-		
	35		4300	3900	2.16	2.49		4.62	-		
	40		4300	3900	1.86	2.19		4.32	-		
	45		4300	3900	2.15	2.48		4.61	-		
	50		4300	3900	1.86	2.19		4.31	-		
	60	4300	3900	1.85	2.18	4.31	-				
	70	4300	3900	1.85	2.18	4.31	-				
80	4300	3900	1.85	2.18	4.31	-					
90	4300	3900	1.85	2.18	4.31	-					
100	4300	3900	1.85	2.18	4.31	-					

- ※ 1 输入转速为额定转速时,使用寿命为20000小时的值
- ※ 2 启动时、停止时容许最大值
- ※ 3 发生撞击时容许最大值(频率最高为1000次)
- ※ 4 运转过程中,额定输入转速容许最大值
- ※ 5 在非连续运转条件下容许最高输入转速
- ※ 6 输入转速为额定转速时,使用寿命为20000个小时的值(作用于轴中央,轴向负荷为0时)
- ※ 7 输入转速为额定转速时,使用寿命为20000个小时的值(作用于轴芯,径向负荷为0时)
- ※ 8 径向负荷容许最大值
- ※ 9 轴向负荷容许最大值
- ※ 10 因减速比和输入轴尺寸的不同而有所不同。

- ※ 1 With nominal input speed, service life is 20,000 hours
- ※ 2 The maximum torque when starting and stopping
- ※ 3 The maximum torque when it receives shock (up to 1000times)
- ※ 4 The maximum average input speed.
- ※ 5 The maximum momentary input speed.
- ※ 6 With this load and nominal input speed, service life will be 20,000 hours (Applied to the output shaft center, at axial load 0)
- ※ 7 With this load and nominal input speed, service life will be 20,000 hours (Applied to the output side bearing, at radial load 0)
- ※ 8 The maximum radial load the reducer can accept
- ※ 9 The maximum axial load the reducer can accept
- ※ 10 The weight may vary slightly model to model.

## ZAF-140

尺寸 Frame size	段位 Stage	减速比 Ratio	容许额定扭矩 Nominal output torque [Nm]	容许最大扭矩 Maximum output torque [Nm]	紧急最大扭矩 Emergency stop torque [Nm]	容许额定输入转速 Nominal input speed [rpm]	容许最高输入转速 Maximum input speed [rpm]	容许径向负荷 Permitted radial load [N]	容许轴向负荷 Permitted axial load [N]	
140	2段 Stage	3	130	260	700	2000	4000	3200	2400	
		4	170	340	950	2000	4000	3500	2700	
		5	200	400	1100	2000	4000	3800	3000	
		6	260	520	1100	2000	4000	4000	3300	
		7	300	600	1100	2000	4000	4200	3500	
		8	300	600	1100	2000	4000	4400	3700	
		9	200	400	750	2000	4000	4600	3900	
		10	200	400	750	2000	4000	4700	4100	
		3段 Stage	15	200	400	750	2000	4000	5400	4900
			16	300	600	1100	2000	4000	5500	5000
	20		300	600	1100	2000	4000	6000	5500	
	25		300	600	1100	2000	4000	6400	6100	
	28		300	600	1100	2000	4000	6700	6400	
	30		200	400	750	2000	4000	6800	6600	
	35		300	600	1100	2000	4000	7200	7000	
	40		300	600	1100	2000	4000	7500	7500	
	45		200	400	750	2000	4000	7800	7900	
	50		300	600	1100	2000	4000	8100	8200	
	60	300	600	1100	2000	4000	8600	8200		
	70	300	600	1100	2000	4000	9100	8200		
80	300	600	1100	2000	4000	9100	8200			
90	200	400	750	2000	4000	9100	8200			
100	200	400	750	2000	4000	9100	8200			

尺寸 Frame size	段位 Stage	减速比 Ratio	容许最大径向负荷 Maximum radial load [N]	容许最大轴向负荷 Maximum axial load [N]	重量 Weight [kg]	惯性力矩 Moment of inertia (≤Φ19) [kgcm <sup>2</sup> ]	惯性力矩 Moment of inertia (≤Φ28) [kgcm <sup>2</sup> ]	惯性力矩 Moment of inertia (≤Φ38) [kgcm <sup>2</sup> ]	惯性力矩 Moment of inertia (≤Φ48) [kgcm <sup>2</sup> ]		
140	2段 Stage	3	9100	8200	19.1	-	23.13	27.50	40.73		
		4	9100	8200		-	18.57	22.94	36.17		
		5	9100	8200		-	16.91	21.28	34.51		
		6	9100	8200		-	16.01	20.38	33.61		
		7	9100	8200		-	15.58	19.95	33.18		
		8	9100	8200		-	15.23	19.61	32.84		
		9	9100	8200		-	14.77	19.41	32.37		
		10	9100	8200		-	14.66	19.03	32.26		
		3段 Stage	15	9100		8200	19.6	6.40	8.00	15.07	-
			16	9100		8200		7.29	8.88	15.96	-
	20		9100	8200	6.22	7.81		14.89	-		
	25		9100	8200	6.15	7.75		14.82	-		
	28		9100	8200	7.09	8.68		15.76	-		
	30		9100	8200	4.99	6.58		13.66	-		
	35		9100	8200	6.09	7.69		14.76	-		
	40		9100	8200	4.95	6.54		13.61	-		
	45		9100	8200	6.07	7.66		14.74	-		
	50		9100	8200	4.93	6.52		13.59	-		
	60	9100	8200	4.92	6.51	13.59	-				
	70	9100	8200	4.91	6.51	13.58	-				
80	9100	8200	4.91	6.50	13.58	-					
90	9100	8200	4.91	6.50	13.57	-					
100	9100	8200	4.91	6.50	13.57	-					

- ※ 1 输入转速为额定转速时,使用寿命为20000小时的值
- ※ 2 启动时、停止时容许最大值
- ※ 3 发生撞击时容许最大值(频率最高为1000次)
- ※ 4 运转过程中,额定输入转速容许最大值
- ※ 5 在非连续运转条件下容许最高输入转速
- ※ 6 输入转速为额定转速时,使用寿命为20000个小时的值(作用于轴中央,轴向负荷为0时)
- ※ 7 输入转速为额定转速时,使用寿命为20000个小时的值(作用于轴芯,径向负荷为0时)
- ※ 8 径向负荷容许最大值
- ※ 9 轴向负荷容许最大值
- ※ 10 因减速比和输入轴尺寸的不同而有所不同。

- ※ 1 With nominal input speed, service life is 20,000 hours
- ※ 2 The maximum torque when starting and stopping
- ※ 3 The maximum torque when it receives shock (up to 1000times)
- ※ 4 The maximum average input speed.
- ※ 5 The maximum momentary input speed.
- ※ 6 With this load and nominal input speed, service life will be 20,000 hours (Applied to the output shaft center, at axial load 0)
- ※ 7 With this load and nominal input speed, service life will be 20,000 hours (Applied to the output side bearing, at radial load 0)
- ※ 8 The maximum radial load the reducer can accept
- ※ 9 The maximum axial load the reducer can accept
- ※ 10 The weight may vary slightly model to model.



## ZAF-060 2段 2stage

输入轴内径 Input shaft bore  $\leq \Phi 8$

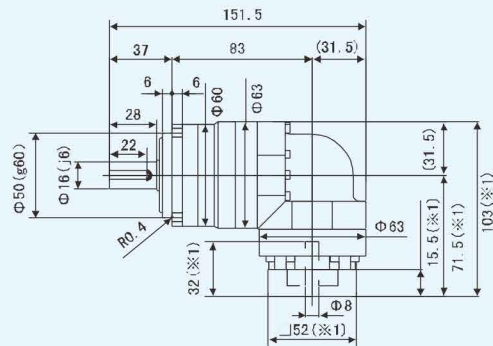
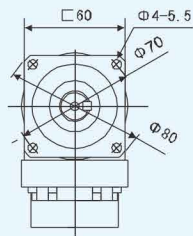

输入轴内径 Input shaft bore  $\leq \Phi 14$

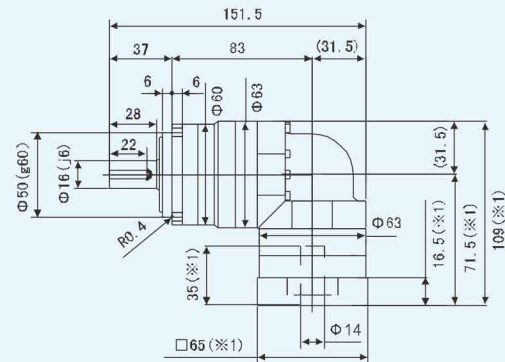
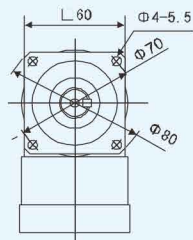

输入轴内径 Input shaft bore  $\leq \Phi 19$

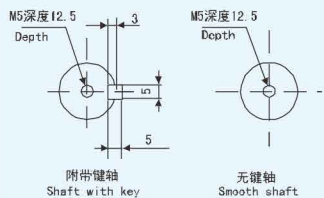
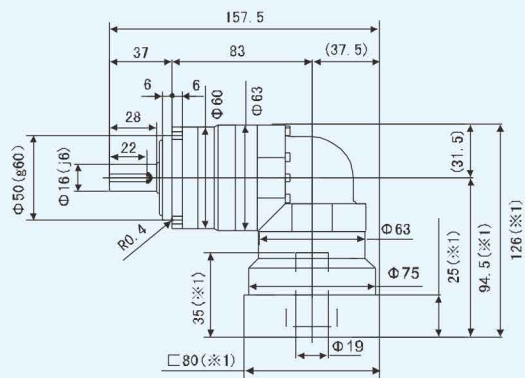
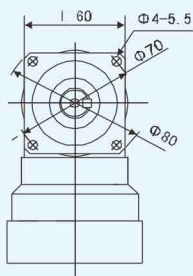

(※1) 随安装马达的不同而有所差异。

(※1) 马达轴径与输入轴径不同时，可插入轴套。

(※1) Length will vary depending motor.

(※1) Bushing will be inserted to adapt to motor shaft.

### ZAF-060 3段 3stage

输入轴内径 Input shaft bore  $\leq \Phi 8$

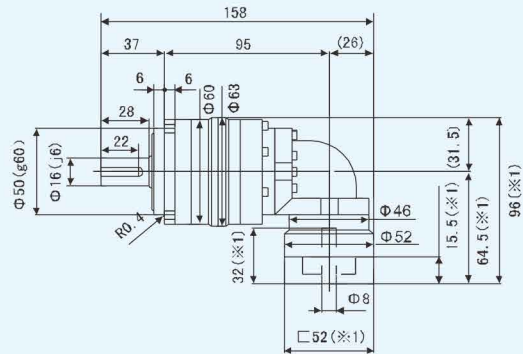
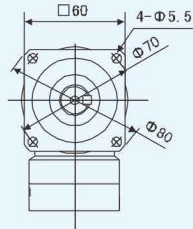

输入轴内径 Input shaft bore  $\leq \Phi 14$

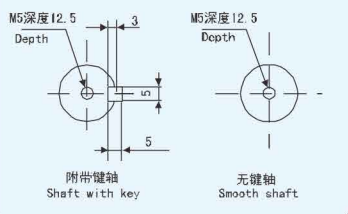
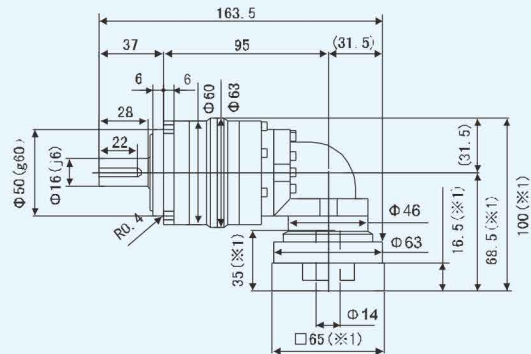
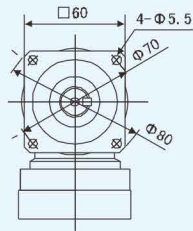

(※1) 随安装马达的不同而有所差异。

(※1) 马达轴径与输入轴径不同时，可插入轴套。

(※1) Length will vary depending motor.

(※1) Bushing will be inserted to adapt to motor shaft.



## ZAF-090 2段 2stage

输入轴内径 Input shaft bore  $\leq \Phi 14$

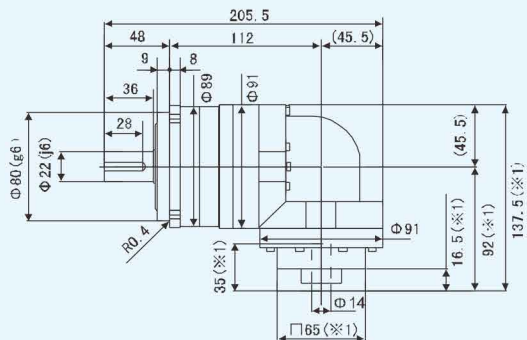
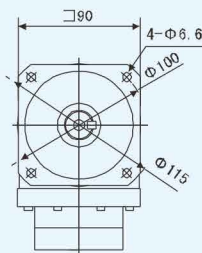

输入轴内径 Input shaft bore  $\leq \Phi 19$

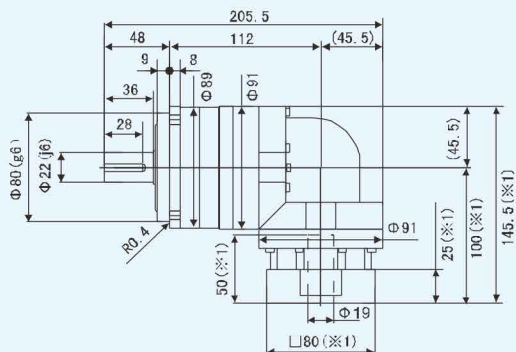
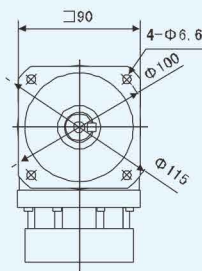

输入轴内径 Input shaft bore  $\leq \Phi 28$

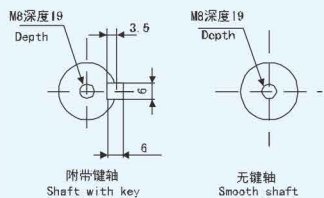
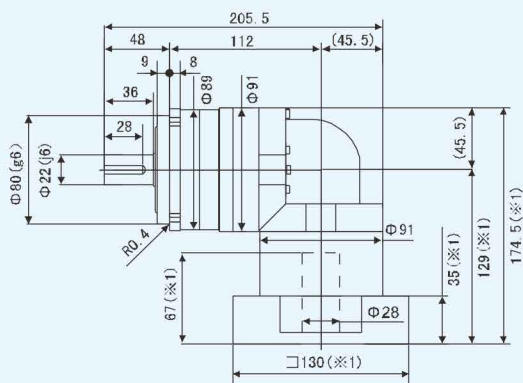
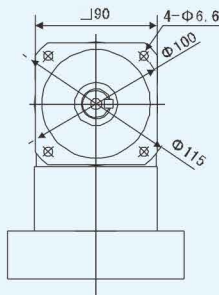

(※1) 随安装马达的不同而有所差异。

(※1) 马达轴径与输入轴径不同时，可插入轴套。

(※1) Length will vary depending motor.

(※1) Bushing will be inserted to adapt to motor shaft.

### ZAF-090 3段 3stage

输入轴内径 Input shaft bore  $\leq \Phi 8$

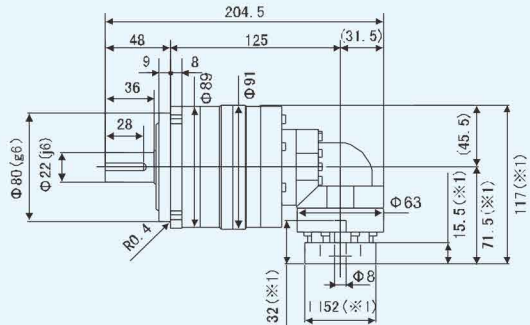
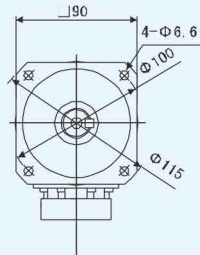

输入轴内径 Input shaft bore  $\leq \Phi 14$

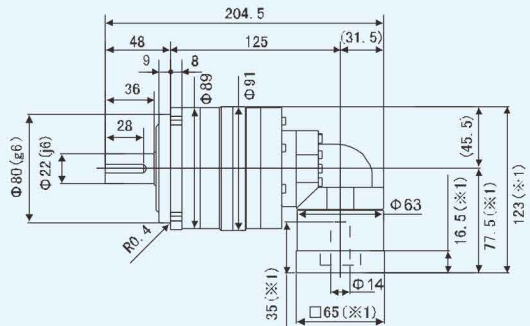
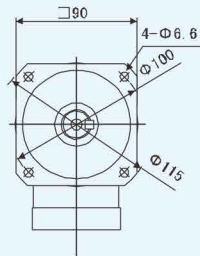

输入轴内径 Input shaft bore  $\leq \Phi 19$

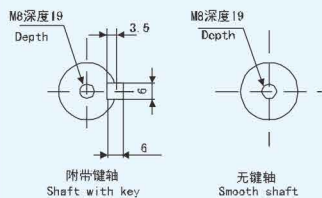
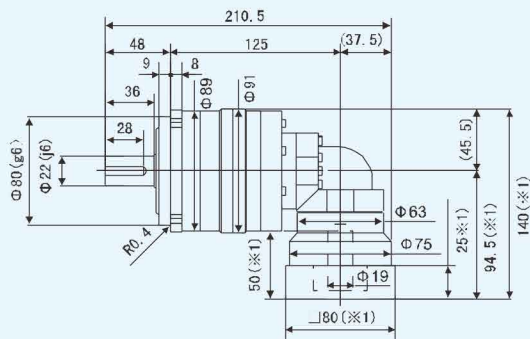
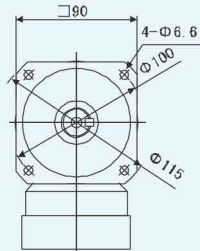

(※1) 随安装马达的不同而有所差异。

(※1) 马达轴径与输入轴径不同时，可插入轴套。

(※1) Length will vary depending motor.

(※1) Bushing will be inserted to adapt to motor shaft.



## ZAF-115 2段 2stage

输入轴内径 Input shaft bore  $\leq \Phi 19$

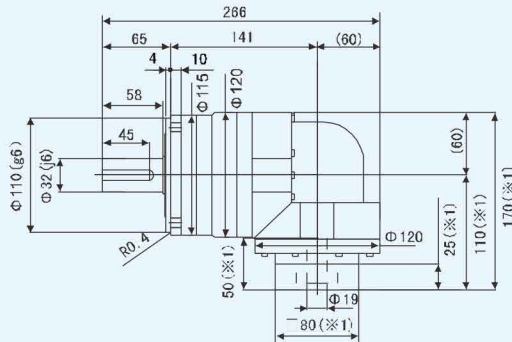
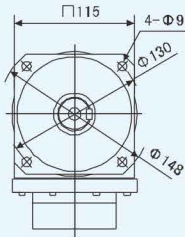

输入轴内径 Input shaft bore  $\leq \Phi 28$

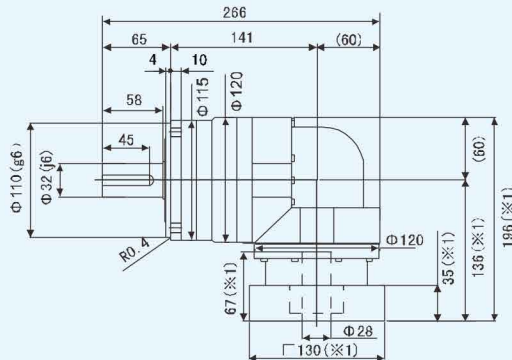
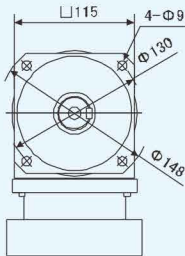

输入轴内径 Input shaft bore  $\leq \Phi 38$

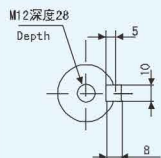
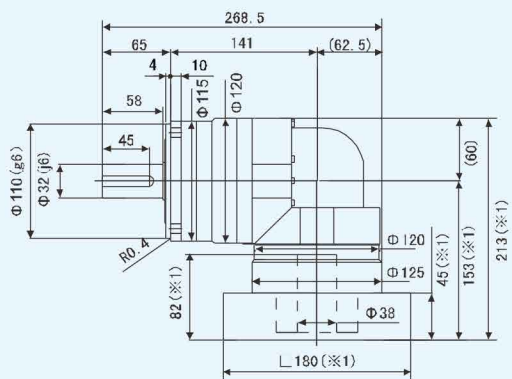
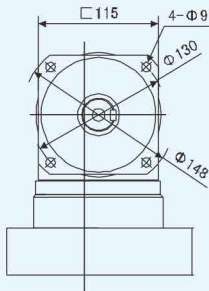

附带键轴  
Shaft with key



无键轴  
Smooth shaft

(※1) 随安装马达的不同而有所差异。

(※1) 马达轴径与输入轴径不同时，可插入轴套。

(※1) Length will vary depending motor.

(※1) Bushing will be inserted to adapt to motor shaft.

### ZAF-115 3段 3stage

输入轴内径 Input shaft bore  $\leq \Phi 14$

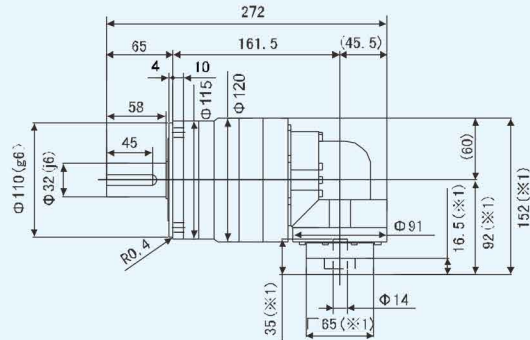
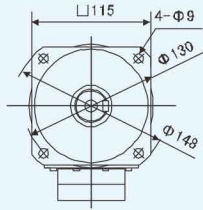

输入轴内径 Input shaft bore  $\leq \Phi 19$

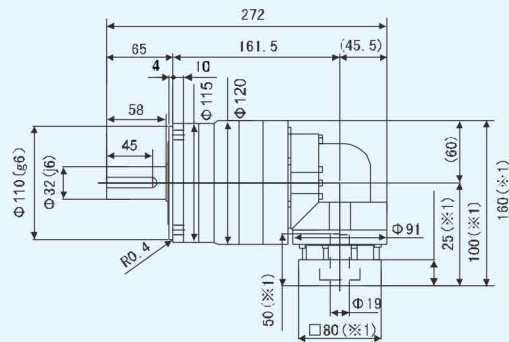
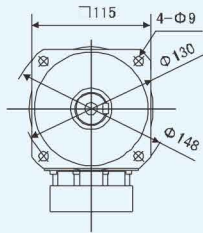

输入轴内径 Input shaft bore  $\leq \Phi 28$

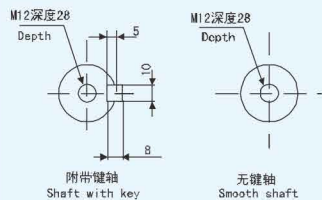
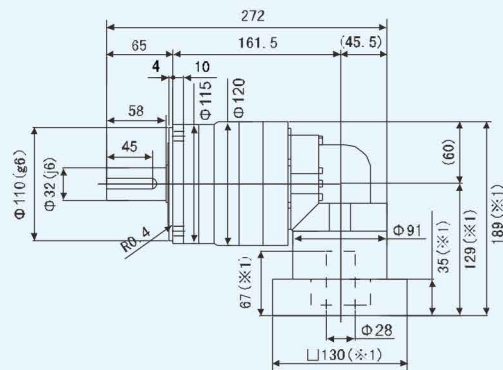
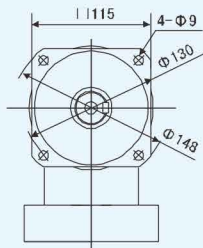

(※1) 随安装马达的不同而有所差异。

(※1) 马达轴径与输入轴径不同时，可插入轴套。

(※1) Length will vary depending motor.

(※1) Bushing will be inserted to adapt to motor shaft.



### ZAF-140 2段 2stage

输入轴内径 Input shaft bore  $\leq \Phi 28$

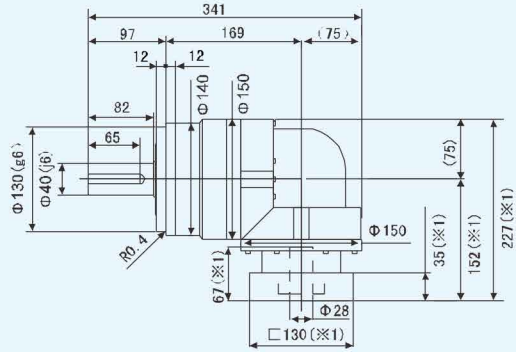
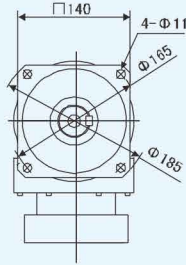

输入轴内径 Input shaft bore  $\leq \Phi 38$

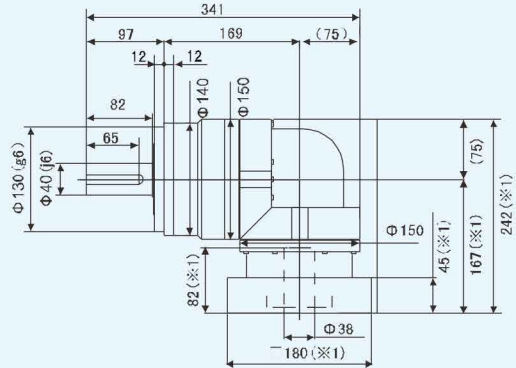
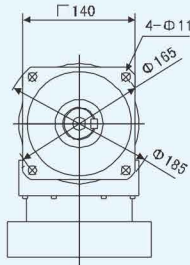

输入轴内径 Input shaft bore  $\leq \Phi 48$

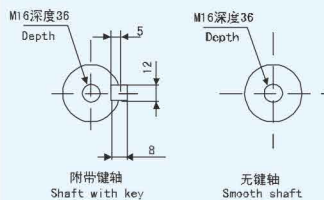
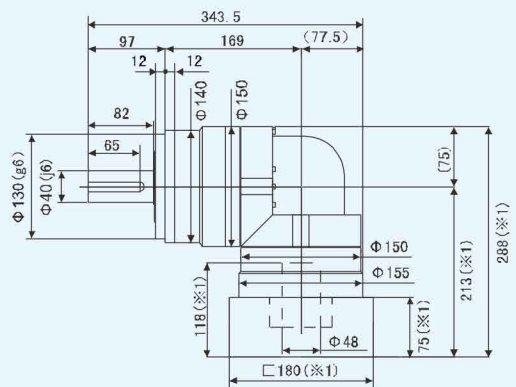
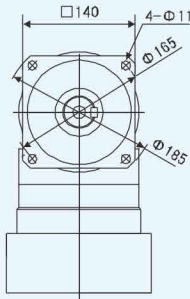

(※1) 随安装马达的不同而有所差异。

(※1) 马达轴径与输入轴径不同时，可插入轴套。

(※1) Length will vary depending motor.

(※1) Bushing will be inserted to adapt to motor shaft.

### ZAF-140 3段 3stage

输入轴内径 Input shaft bore  $\leq \Phi 19$

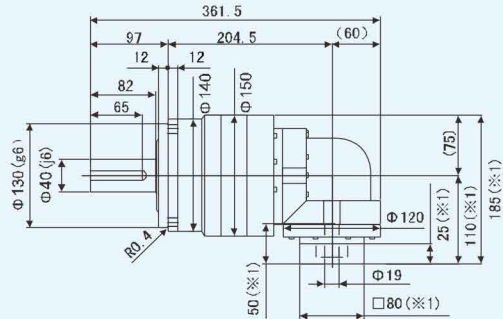
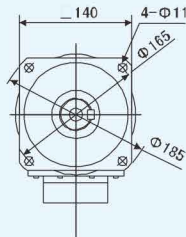

输入轴内径 Input shaft bore  $\leq \Phi 28$

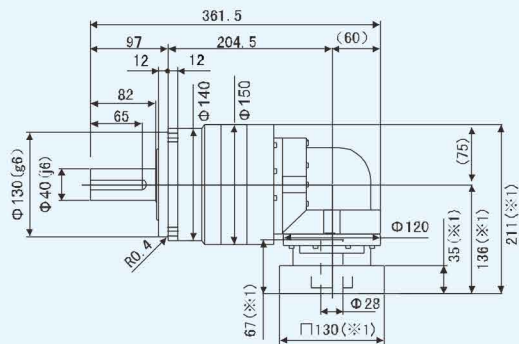
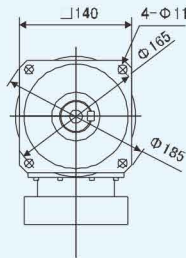

输入轴内径 Input shaft bore  $\leq \Phi 38$

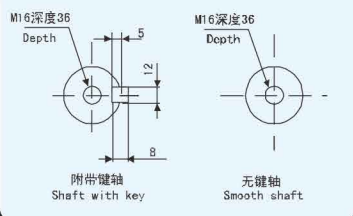
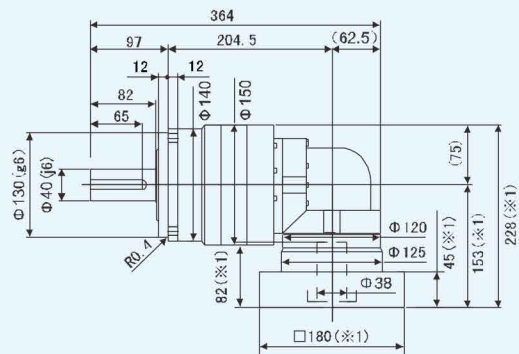
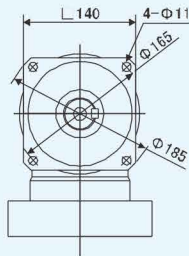

(※1) 随安装马达的不同而有所差异。

(※1) 马达轴径与输入轴径不同时，可插入轴套。

(※1) Length will vary depending motor.

(※1) Bushing will be inserted to adapt to motor shaft.



## ZAF-060

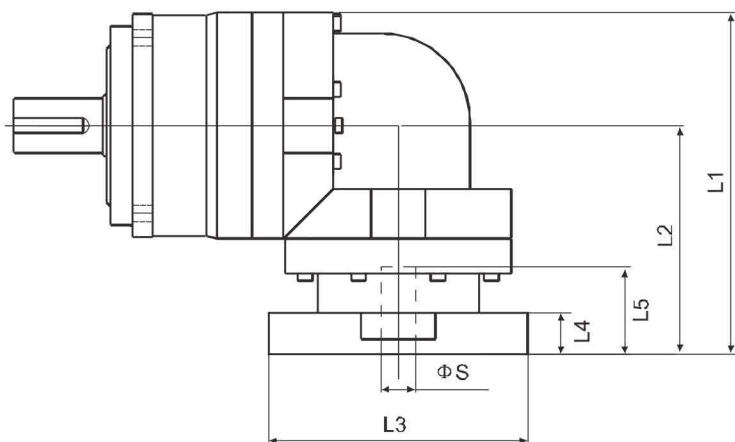

型号 Model number	**: 轴套编号 **: Adapter code	2段 Stage					3段 Stage				
		L1	L2	L3	L4	L5	L1	L2	L3	L4	L5
ZAF-060-□-□-8** [输入轴内径Input shaft bore S=8]	AA·AC·AD·AF·AG	103	71.5	□52	15.5	32	96	64.5	□52	15.5	32
	AB·AE·AH·AJ·AK	108	76.5	□52	20.5	37	101	69.5	□52	20.5	37
	BA·BB·BD·BE	103	71.5	□60	15.5	32	96	64.5	□60	15.5	32
	BC·BF	108	76.5	□60	20.5	37	101	69.5	□60	20.5	37
	CA	108	76.5	□70	20.5	37	101	69.5	□70	20.5	37
ZAF-060-□-□-14** [输入轴内径Input shaft bore 8<S≤14]	BA·BB·BD·BE·BF·BG·BJ·BK	109	77.5	□65	16.5	35	100	68.5	□65	16.5	35
	BC·BH	114	82.5	□65	21.5	40	105	73.5	□65	21.5	40
	BL	119	87.5	□65	26.5	45	110	78.5	□65	26.5	45
	CA	109	77.5	□70	16.5	35	100	68.5	□70	16.5	35
	CB	114	82.5	□70	21.5	40	105	73.5	□70	21.5	40
	DA·DB·DC·DD·DF·DH	109	77.5	□80	16.5	35	100	68.5	□80	16.5	35
	DE	114	82.5	□80	21.5	40	105	73.5	□80	21.5	40
	DG	119	87.5	□80	26.5	45	110	78.5	□80	26.5	45
	EA·EB·EC	109	77.5	□90	16.5	35	100	68.5	□90	16.5	35
	ED	119	87.5	□90	26.5	45	110	78.5	□90	26.5	45
	FA	109	77.5	□100	16.5	35	100	68.5	□100	16.5	35
	GA	109	77.5	□115	16.5	35	100	68.5	□115	16.5	35
ZAF-060-  -   -19** [输入轴内径Input shaft bore 14<S≤19]	DA·DB·DC	126	94.5	□80	25	50	-	-	-	-	-
	DD	136	104.5	□80	35	60	-	-	-	-	-
	DE	131	99.5	□80	30	55	-	-	-	-	-
	EA	131	99.5	□90	30	55	-	-	-	-	-
	EB	126	94.5	□90	25	50	-	-	-	-	-
	EC	136	104.5	□90	35	60	-	-	-	-	-
	FA	126	94.5	□100	25	50	-	-	-	-	-
	FB	136	104.5	□100	35	60	-	-	-	-	-
	GA·GC	131	99.5	□115	30	55	-	-	-	-	-
	GB·GD	126	94.5	□115	25	50	-	-	-	-	-
	HA	126	94.5	□130	25	50	-	-	-	-	-
	HB	141	109.5	□130	40	65	-	-	-	-	-
	HC·HD·HE	131	99.5	□130	30	55	-	-	-	-	-

※1 2段减速: 1/3~1/10; 3段减速: 1/15~1/100  
 ※2 马达轴径与输入轴径不同时, 可插入轴套

※1 2 stage reduction : 1/3~1/10, 3 stage reduction: 1/15~1/100  
 ※2 Bushing will be inserted to adapt to motor shaft.

## ZAF-090

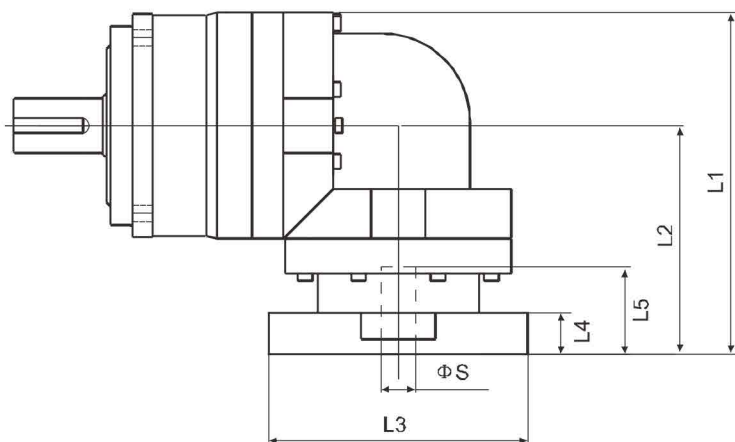

型号 Model number	**: 轴套编号 **: Adapter code	2段 Stage					3段 Stage				
		L1	L2	L3	L4	L5	L1	L2	L3	L4	L5
ZAF-090-□-□-8** [输入轴内径Input shaft bore $S \leq 8$ ]	AA · AC · AD · AF · AG	-	-	-	-	-	117	71.5	□52	15.5	32
	AB · AE · AH · AJ · AK	-	-	-	-	-	122	76.5	□52	20.5	37
	BA · BB · BD · BE	-	-	-	-	-	117	71.5	□60	15.5	32
	BC · BF	-	-	-	-	-	122	76.5	□60	20.5	37
	CA	-	-	-	-	-	122	76.5	□70	20.5	37
ZAF-090-□-□-14** [输入轴内径Input shaft bore $8 < S \leq 14$ ]	BA · BB · BD · BE · BF · BG · BJ · BK	137.5	92	□65	16.5	35	123	77.5	□65	16.5	35
	BC · BH	142.5	97	□65	21.5	40	128	82.5	□65	21.5	40
	BL	147.5	102	□65	26.5	45	133	87.5	□65	26.5	45
	CA	137.5	92	□70	16.5	35	123	77.5	□70	16.5	35
	CB	142.5	97	□70	21.5	40	128	82.5	□70	21.5	40
	DA · DB · DC · DD · DF · DH	137.5	92	□80	16.5	35	123	77.5	□80	16.5	35
	DE	142.5	97	□80	21.5	40	128	82.5	□80	21.5	40
	DG	147.5	102	□80	26.5	45	133	87.5	□80	26.5	45
	EA · EB · EC	137.5	92	□90	16.5	35	123	77.5	□90	16.5	35
	ED	147.5	102	□90	26.5	45	133	87.5	□90	26.5	45
	FA	137.5	92	□100	16.5	35	123	77.5	□100	16.5	35
	GA	137.5	92	□115	16.5	35	123	77.5	□115	16.5	35
	ZAF-090-□-□-19** [输入轴内径Input shaft bore $14 < S \leq 19$ ]	DA · DB · DC	145.5	100	□80	25	50	140	94.5	□80	25
DD		155.5	110	□80	35	60	150	104.5	□80	35	60
DE		150.5	105	□80	30	55	145	99.5	□80	30	55
EA		150.5	105	□90	30	55	145	99.5	□90	30	55
EB		145.5	100	□90	25	50	140	94.5	□90	25	50
EC		155.5	110	□90	35	60	150	104.5	□90	35	60
FA		145.5	100	□100	25	50	140	94.5	□100	25	50
FB		155.5	110	□100	35	60	150	104.5	□100	35	60
GA · GC		150.5	105	□115	30	55	145	99.5	□115	30	55
GB · GD		145.5	100	□115	25	50	140	94.5	□115	25	50
HA		145.5	100	□130	25	50	140	94.5	□130	25	50
HB		160.5	115	□130	40	65	155	109.5	□130	40	65
HC · HD · HE		150.5	105	□130	30	55	145	99.5	□130	30	55
ZAF-090-□-□-28** [输入轴内径Input shaft bore $19 < S \leq 28$ ]	FA · FB · FC	174.5	129	□100	35	67	-	-	-	-	-
	GA · GB · GC · GD · GE · GF · GG	174.5	129	□115	35	67	-	-	-	-	-
	HA · HC · HD	174.5	129	□130	35	67	-	-	-	-	-
	HB	184.5	139	□130	45	77	-	-	-	-	-
	JA · JB · JC	174.5	129	□150	35	67	-	-	-	-	-
	KA · KB	174.5	129	□180	35	67	-	-	-	-	-
	LA	174.5	129	□200	35	67	-	-	-	-	-
MA	174.5	129	□220	35	67	-	-	-	-	-	

※1 2段减速: 1/3~1/10; 3段减速: 1/15~1/100  
 ※2 马达轴径与输入轴径不同时, 可插入轴套

※1 2 stage reduction : 1/3~1/10, 3 stage reduction: 1/15~1/100  
 ※2 Bushing will be inserted to adapt to motor shaft.



## ZAF-115

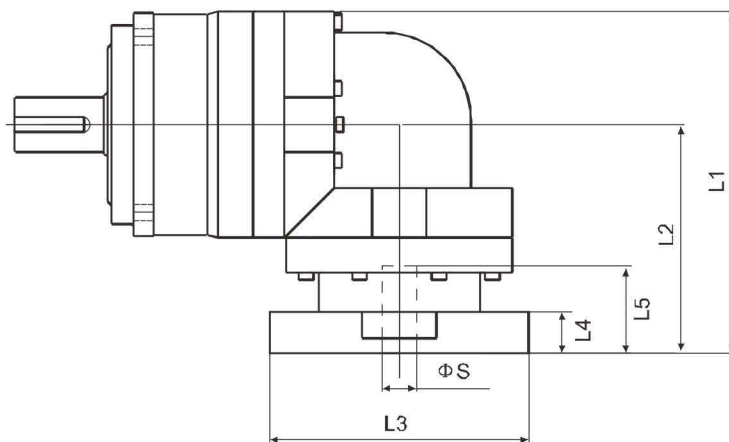

型号 Model number	**: 轴套编号 **: Adapter code	2段 Stage					3段 Stage				
		L1	L2	L3	L4	L5	L1	L2	L3	L4	L5
ZAF-115-□-□-14** [输入轴内径Input shaft bore S≤14]	BA · BB · BD · BE · BF · BG · BJ · BK	-	-	-	-	-	152	92	□65	16.5	35
	BC · BH	-	-	-	-	-	157	97	□65	21.5	40
	BL	-	-	-	-	-	162	102	□65	26.5	45
	CA	-	-	-	-	-	152	92	□70	16.5	35
	CB	-	-	-	-	-	157	97	□70	21.5	40
	DA · DB · DC · DD · DF · DH	-	-	-	-	-	152	92	□80	16.5	35
	DE	-	-	-	-	-	157	97	□80	21.5	40
	DG	-	-	-	-	-	162	102	□80	26.5	45
	EA · EB · EC	-	-	-	-	-	152	92	□90	16.5	35
	ED	-	-	-	-	-	162	102	□90	26.5	45
	FA	-	-	-	-	-	152	92	□100	16.5	35
GA	-	-	-	-	-	152	92	□115	16.5	35	
ZAF-115-□-□-19** [输入轴内径Input shaft bore 14<S≤19]	DA · DB · DC	170	110	□80	25	50	160	100	□80	25	50
	DD	180	120	□80	35	60	170	110	□80	35	60
	DE	175	115	□80	30	55	165	105	□80	30	55
	EA	175	115	□90	30	55	165	105	□90	30	55
	EB	170	110	□90	25	50	160	100	□90	25	50
	EC	180	120	□90	35	60	170	110	□90	35	60
	FA	170	110	□100	25	50	160	100	□100	25	50
	FB	180	120	□100	35	60	170	110	□100	35	60
	GA · GC	175	115	□115	30	55	165	105	□115	30	55
	GB · GD	170	110	□115	25	50	160	100	□115	25	50
	HA	170	110	□130	25	50	160	100	□130	25	50
HB	185	125	□130	40	65	175	115	□130	40	65	
HC · HD · HE	175	115	□130	30	55	165	105	□130	30	55	
ZAF-115-□-□-28** [输入轴内径Input shaft bore 19<S≤28]	FA · FB · FC	196	136	□100	35	67	189	129	□100	35	67
	GA · GB · GC · GD · GE · GF · GG	196	136	□115	35	67	189	129	□115	35	67
	HA · HC · HD	196	136	□130	35	67	189	129	□130	35	67
	HB	206	146	□130	45	77	199	139	□130	45	77
	JA · JB · JC	196	136	□150	35	67	189	129	□150	35	67
	KA · KB	196	136	□180	35	67	189	129	□180	35	67
	LA	196	136	□200	35	67	189	129	□200	35	67
MA	196	136	□220	35	67	189	129	□220	35	67	
ZAF-115-□-□-38** [输入轴内径Input shaft bore 28<S≤38]	HA	213	153	□130	45	82	-	-	-	-	-
	HB	208	148	□130	40	77	-	-	-	-	-
	JA	213	153	□150	45	82	-	-	-	-	-
	KA · KB · KC	213	153	□180	45	82	-	-	-	-	-
	LA	213	153	□200	45	82	-	-	-	-	-
	LB	213	163	□200	55	92	-	-	-	-	-
	MA · MB	213	153	□220	45	82	-	-	-	-	-
NA	213	153	□250	45	82	-	-	-	-	-	

※1 2段减速: 1/3~1/10; 3段减速: 1/15~1/100  
 ※2 马达轴径与输入轴径不同时, 可插入轴套

※1 2 stage reduction : 1/3~1/10, 3 stage reduction: 1/15~1/100  
 ※2 Bushing will be inserted to adapt to motor shaft.

## ZAF-140

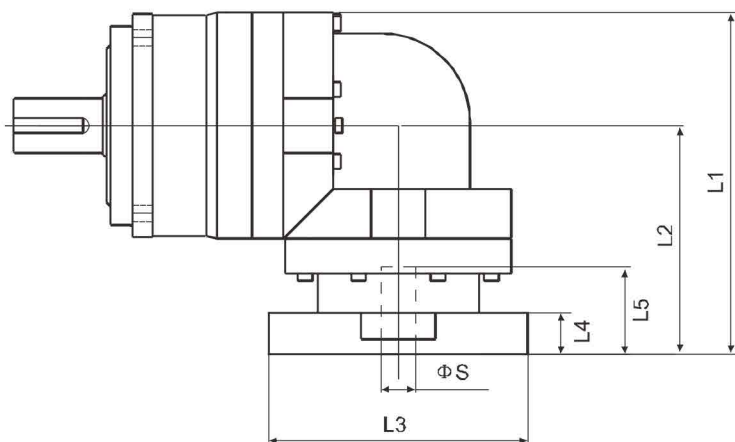

型号 Model number	**: 轴套编号 **: Adapter code	2段 Stage					3段 Stage				
		L1	L2	L3	L4	L5	L1	L2	L3	L4	L5
ZAF-140-□-□-19** [输入轴内径Input shaft bore S≤19]	DA · DB · DC	-	-	-	-	-	185	110	□80	25	50
	DD	-	-	-	-	-	195	120	□80	35	60
	DE	-	-	-	-	-	190	115	□80	30	55
	EA	-	-	-	-	-	190	115	□90	30	55
	EB	-	-	-	-	-	185	110	□90	25	50
	EC	-	-	-	-	-	195	120	□90	35	60
	FA	-	-	-	-	-	185	110	□100	25	50
	FB	-	-	-	-	-	195	120	□100	35	60
	GA · GC	-	-	-	-	-	190	115	□115	30	55
	GB · GD	-	-	-	-	-	185	110	□115	25	50
	HA	-	-	-	-	-	185	110	□130	25	50
	HB	-	-	-	-	-	200	125	□130	40	65
	HC · HD · HE	-	-	-	-	-	190	115	□130	30	55
ZAF-140-□-□-28** [输入轴内径Input shaft bore 19<S≤28]	FA · FB · FC	227	152	□100	35	67	211	136	□100	35	67
	GA · GB · GC · GD · GE · GF · GG	227	152	□115	35	67	211	136	□115	35	67
	HA · HC · HD	227	152	□130	35	67	211	136	□130	35	67
	HB	227	162	□130	45	77	221	146	□130	45	77
	JA · JB · JC	227	152	□150	35	67	211	136	□150	35	67
	KA · KB	227	152	□180	35	67	211	136	□180	35	67
	LA	227	152	□200	35	67	211	136	□200	35	67
ZAF-140-□-□-38** [输入轴内径Input shaft bore 28<S≤38]	MA	227	152	□220	35	67	211	136	□220	35	67
	HA	242	167	□130	45	82	228	153	□130	45	82
	HB	237	162	□130	40	77	223	148	□130	40	77
	JA	242	167	□150	45	82	228	153	□150	45	82
	KA · KB · KC	242	167	□180	45	82	228	153	□180	45	82
	LA	242	167	□200	45	82	228	153	□200	45	82
	LB	252	177	□200	55	92	238	163	□200	55	92
ZAF-140-□-□-48** [输入轴内径Input shaft bore 38<S≤48]	MA · MB	242	167	□220	45	82	228	153	□220	45	82
	NA	242	167	□250	45	82	228	153	□250	45	82
	KB · KC	268	193	□180	55	98	-	-	-	-	-
	KA	268	213	□180	75	118	-	-	-	-	-
	LA	268	193	□200	55	98	-	-	-	-	-
	MA	268	193	□220	55	98	-	-	-	-	-
	MB	288	213	□220	75	118	-	-	-	-	-
NA	268	213	□250	75	118	-	-	-	-	-	
PA	268	213	□280	75	118	-	-	-	-	-	

※1 2段减速: 1/3~1/10; 3段减速: 1/15~1/100  
 ※2 马达轴径与输入轴径不同时, 可插入轴套

※1 2 stage reduction : 1/3~1/10, 3 stage reduction: 1/15~1/100  
 ※2 Bushing will be inserted to adapt to motor shaft.