

静音

使用斜齿轮实现顺畅安静地运转

Quiet operation

Helical gears contribute to reduce vibration and noise

高精度

齿隙低于3弧分，定位精确

High precision

Standard backlash is 3 arc/min, ideal for precision control.

高刚性，高扭矩

使用整体式滚珠轴承，大大提高刚性和扭矩

High rigidity & torque

High rigidity & high torque were achieved by uncaged needle roller bearings

法兰、轴套方式

可以安装到任何一台马达上

Adapter-bushing connection

Can be attached to any motor all over the world.

无润滑油脂泄漏

使用高粘度、不易分离的润滑脂，有效防止润滑脂泄漏

No grease leakage

Perfect solving using high viscosity anti-separation grease.

维护方便

在产品寿命期内无需更换润滑脂，安装更便捷

Maintenance-free

No need to replace the grease for the life of the unit. Can be attached in any position.

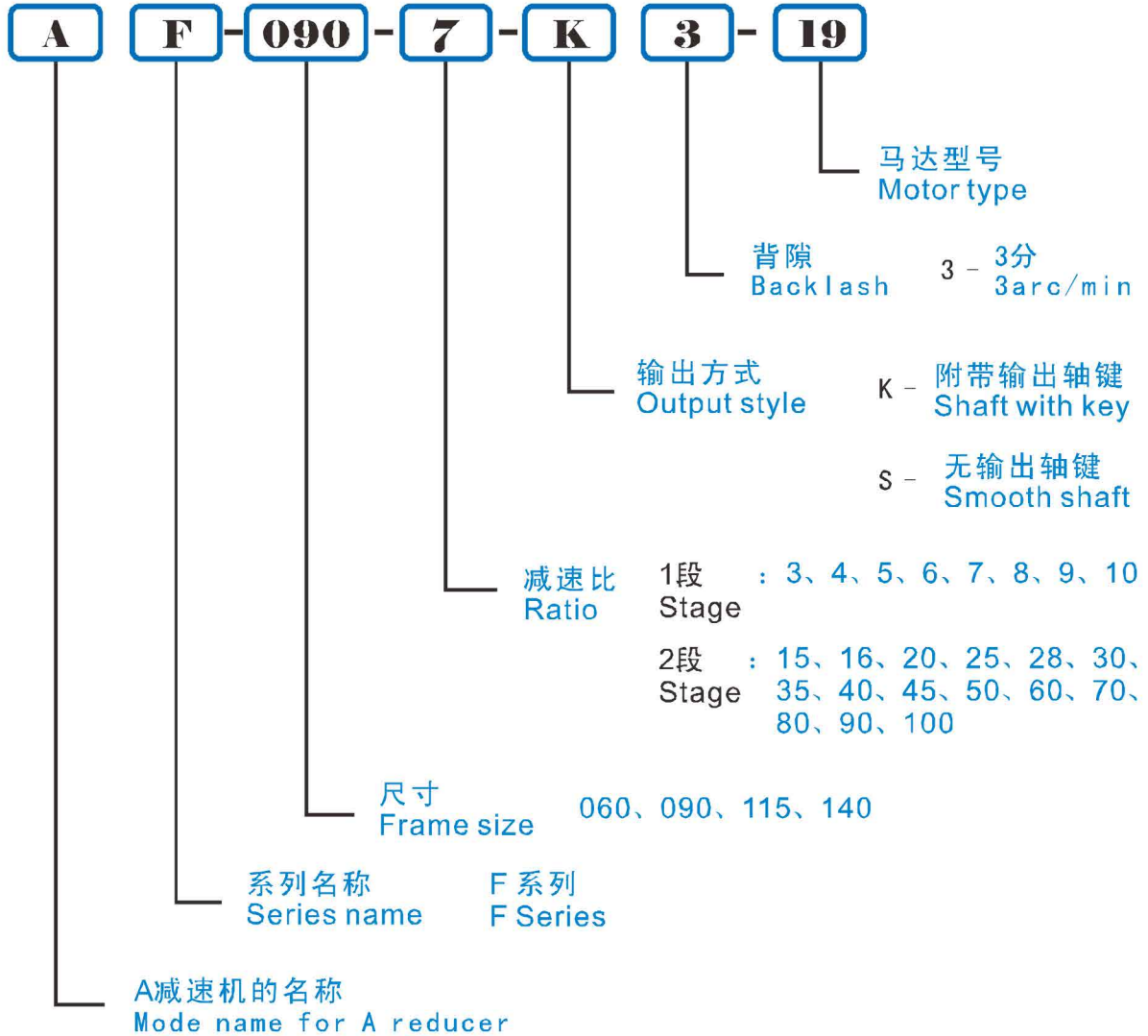

如有不明白之处，欢迎咨询。
Please contact us for more information.

AF-060

尺寸 Frame size	段位 Stage	减速比 Ratio	※1	※2	※3	※4	※5	※6	※7	
			容许额定扭矩 Nominal output torque [Nm]	容许最大扭矩 Maximum output torque [Nm]	紧急最大扭矩 Emergency stop torque [Nm]	容许额定输入转速 Nominal input speed [rpm]	容许最高输入转速 Maximum input speed [rpm]	容许径向负荷 Permitted radial load [N]	容许轴向负荷 Permitted axial load [N]	
060	1段 Stage	3	18	35	80	3000	6000	430	310	
		4	27	50	100	3000	6000	470	360	
		5	27	50	100	3000	6000	510	390	
		6	27	50	100	3000	6000	540	430	
		7	27	50	100	3000	6000	570	460	
		8	27	50	100	3000	6000	600	480	
		9	18	35	80	3000	6000	620	510	
		10	18	35	80	3000	6000	640	530	
		2段 Stage	15	18	35	80	3000	6000	740	630
			16	27	50	100	3000	6000	750	650
	20		27	50	100	3000	6000	810	720	
	25		27	50	100	3000	6000	870	790	
	28		27	50	100	3000	6000	910	830	
	30		18	35	80	3000	6000	930	860	
	35		27	50	100	3000	6000	980	920	
	40		27	50	100	3000	6000	1000	970	
	45		18	35	80	3000	6000	1100	1000	
	50		27	50	100	3000	6000	1100	1100	
	60	27	50	100	3000	6000	1200	1100		
	70	27	50	100	3000	6000	1200	1100		
80	27	50	100	3000	6000	1200	1100			
90	18	35	80	3000	6000	1200	1100			
100	18	35	80	3000	6000	1200	1100			

尺寸 Frame size	段位 Stage	减速比 Ratio	※8	※9	※10	重量 Weight [kg]	惯性力矩 Moment of inertia ($\leq \Phi 8$) [kgcm ²]	惯性力矩 Moment of inertia ($\leq \Phi 14$) [kgcm ²]	惯性力矩 Moment of inertia ($\leq \Phi 19$) [kgcm ²]		
			容许最大径向负荷 Maximum radial load [N]	容许最大轴向负荷 Maximum axial load [N]							
060	1段 Stage	3	1200	1100	1.4	0.14	0.22	0.43			
		4	1200	1100		0.095	0.17	0.38			
		5	1200	1100		0.077	0.16	0.36			
		6	1200	1100		0.068	0.15	0.36			
		7	1200	1100		0.062	0.14	0.35			
		8	1200	1100		0.059	0.14	0.35			
		9	1200	1100		0.057	0.14	0.34			
		10	1200	1100		0.056	0.14	0.34			
		2段 Stage	15	1200		1100	1.6	0.055	0.14	-	
			16	1200		1100		0.057	0.14	-	
	20		1200	1100	0.054	0.13		-			
	25		1200	1100	0.053	0.13		-			
	28		1200	1100	0.055	0.14		-			
	30		1200	1100	0.049	0.13		-			
	35		1200	1100	0.053	0.13		-			
	40		1200	1100	0.049	0.13		-			
	45		1200	1100	0.053	0.13		-			
	50		1200	1100	0.049	0.13		-			
	60	1200	1100	0.049	0.13	-					
	70	1200	1100	0.049	0.13	-					
80	1200	1100	0.049	0.13	-						
90	1200	1100	0.049	0.13	-						
100	1200	1100	0.049	0.13	-						

- ※ 1 输入转速为额定转速时，使用寿命为20000小时的值
- ※ 2 启动时、停止时容许的最大值
- ※ 3 发生撞击时容许的最大值（频率最高为1000次）
- ※ 4 运转过程中，额定输入转速容许的最大值
- ※ 5 在非连续运转条件下容许的最高输入转速
- ※ 6 输入转速为额定转速时，使用寿命为20000个小时的值（作用于轴中央，轴向负荷为0时）
- ※ 7 输入转速为额定转速时，使用寿命为20000个小时的值（作用于轴芯，径向负荷为0时）
- ※ 8 径向负荷容许最大值
- ※ 9 轴向负荷容许最大值
- ※ 10 因减速比和输入轴尺寸的不同而有所不同。

- ※ 1 With nominal input speed, service life is 20,000 hours
- ※ 2 The maximum torque when starting and stopping
- ※ 3 The maximum torque when it receives shock (up to 1000times)
- ※ 4 The maximum average input speed.
- ※ 5 The maximum momentary input speed.
- ※ 6 With this load and nominal input speed, service life will be 20,000 hours (Applied to the output shaft center, at axial load 0)
- ※ 7 With this load and nominal input speed, service life will be 20,000 hours (Applied to the output side bearing, at radial load 0)
- ※ 8 The maximum radial load the reducer can accept
- ※ 9 The maximum axial load the reducer can accept
- ※ 10 The weight may vary slightly model to model.

AF-090

尺寸 Frame size	段位 Stage	减速比 Ratio	※1	※2	※3	※4	※5	※6	※7	
			容许额定扭矩 Nominal output torque [Nm]	容许最大扭矩 Maximum output torque [Nm]	紧急最大扭矩 Emergency stop torque [Nm]	容许额定输入转速 Nominal input speed [rpm]	容许最高输入转速 Maximum input speed [rpm]	容许径向负荷 Permitted radial load [N]	容许轴向负荷 Permitted axial load [N]	
090	1段 Stage	3	50	80	200	3000	6000	810	930	
		4	75	125	250	3000	6000	890	1100	
		5	75	125	250	3000	6000	960	1200	
		6	75	125	250	3000	6000	1000	1300	
		7	75	125	250	3000	6000	1100	1300	
		8	75	125	250	3000	6000	1100	1400	
		9	50	80	200	3000	6000	1200	1500	
		10	50	80	200	3000	6000	1200	1600	
		2段 Stage	15	50	80	200	3000	6000	1400	1900
			16	75	125	250	3000	6000	1400	1900
	20		75	125	250	3000	6000	1500	2100	
	25		75	125	250	3000	6000	1600	2200	
	28		75	125	250	3000	6000	1700	2200	
	30		50	80	200	3000	6000	1700	2200	
	35		75	125	250	3000	6000	1800	2200	
	40		75	125	250	3000	6000	1900	2200	
	45		50	80	200	3000	6000	2000	2200	
	50		75	125	250	3000	6000	2100	2200	
	60	75	125	250	3000	6000	2200	2200		
	70	75	125	250	3000	6000	2300	2200		
80	75	125	250	3000	6000	2400	2200			
90	50	80	200	3000	6000	2400	2200			
100	50	80	200	3000	6000	2400	2200			

尺寸 Frame size	段位 Stage	减速比 Ratio	※8	※9	重量 Weight [kg]	※10	惯性力矩 Moment of inertia ($\leq \Phi 8$) [kgcm ²]	惯性力矩 Moment of inertia ($\leq \Phi 14$) [kgcm ²]	惯性力矩 Moment of inertia ($\leq \Phi 19$) [kgcm ²]	惯性力矩 Moment of inertia ($\leq \Phi 28$) [kgcm ²]	
			容许最大径向负荷 Maximum radial load [N]	容许最大轴向负荷 Maximum axial load [N]		容许最大径向负荷 Maximum radial load [N]	容许最大轴向负荷 Maximum axial load [N]				
090	1段 Stage	3	2400	2200	3.7	-	0.72	1.2	3.2		
		4	2400	2200		-	0.49	0.95	3.0		
		5	2400	2200		-	0.40	0.86	2.9		
		6	2400	2200		-	0.36	0.82	2.8		
		7	2400	2200		-	0.32	0.79	2.8		
		8	2400	2200		-	0.31	0.77	2.8		
		9	2400	2200		-	0.29	0.76	2.8		
		10	2400	2200		-	0.29	0.75	2.8		
		2段 Stage	15	2400		2200	4.2	0.13	0.28	0.72	-
			16	2400		2200		0.15	0.30	0.74	-
	20		2400	2200	0.13	0.28		0.72	-		
	25		2400	2200	0.12	0.28		0.71	-		
	28		2400	2200	0.14	0.29		0.73	-		
	30		2400	2200	0.10	0.25		0.70	-		
	35		2400	2200	0.12	0.27		0.71	-		
	40		2400	2200	0.099	0.25		0.70	-		
	45		2400	2200	0.12	0.27		0.71	-		
	50		2400	2200	0.098	0.25		0.69	-		
	60	2400	2200	0.098	0.25	0.69	-				
	70	2400	2200	0.097	0.25	0.69	-				
80	2400	2200	0.097	0.25	0.69	-					
90	2400	2200	0.097	0.25	0.69	-					
100	2400	2200	0.097	0.25	0.69	-					

- ※ 1 输入转速为额定转速时,使用寿命为20000小时的值
- ※ 2 启动时、停止时容许的最大值
- ※ 3 发生撞击时容许的最大值(频率最高为1000次)
- ※ 4 运转过程中,额定输入转速容许的最大值
- ※ 5 在非连续运转条件下容许的最高输入转速
- ※ 6 输入转速为额定转速时,使用寿命为20000个小时的值(作用于轴中央,轴向负荷为0时)
- ※ 7 输入转速为额定转速时,使用寿命为20000个小时的值(作用于轴芯,径向负荷为0时)
- ※ 8 径向负荷容许最大值
- ※ 9 轴向负荷容许最大值
- ※ 10 因减速比和输入轴尺寸的不同而有所不同。

- ※ 1 With nominal input speed, service life is 20,000 hours
- ※ 2 The maximum torque when starting and stopping
- ※ 3 The maximum torque when it receives shock (up to 1000times)
- ※ 4 The maximum average input speed.
- ※ 5 The maximum momentary input speed.
- ※ 6 With this load and nominal input speed, service life will be 20,000 hours (Applied to the output shaft center, at axial load 0)
- ※ 7 With this load and nominal input speed, service life will be 20,000 hours (Applied to the output side bearing, at radial load 0)
- ※ 8 The maximum radial load the reducer can accept
- ※ 9 The maximum axial load the reducer can accept
- ※ 10 The weight may vary slightly model to model.

AF-115

尺寸 Frame size	段位 Stage	减速比 Ratio	※1	※2	※3	※4	※5	※6	※7	
			容许额定扭矩 Nominal output torque [Nm]	容许最大扭矩 Maximum output torque [Nm]	紧急最大扭矩 Emergency stop torque [Nm]	容许额定输入转速 Nominal input speed [rpm]	容许最高输入转速 Maximum input speed [rpm]	容许径向负荷 Permitted radial load [N]	容许轴向负荷 Permitted axial load [N]	
115	1段 Stage	3	120	225	500	3000	6000	1300	1500	
		4	120	330	625	3000	6000	1500	1700	
		5	180	330	625	3000	6000	1600	1900	
		6	180	330	625	3000	6000	1700	2000	
		7	180	330	625	3000	6000	1800	2100	
		8	180	330	625	3000	6000	1900	2300	
		9	120	225	500	3000	6000	1900	2400	
		10	120	225	500	3000	6000	2000	2500	
		2段 Stage	15	120	225	500	3000	6000	2300	3000
			16	180	330	625	3000	6000	2300	3100
	20		180	330	625	3000	6000	2500	3400	
	25		180	330	625	3000	6000	2700	3700	
	28		180	330	625	3000	6000	2800	3900	
	30		120	225	500	3000	6000	2900	3900	
	35		180	330	625	3000	6000	3000	3900	
	40		180	330	625	3000	6000	3200	3900	
	45		120	225	500	3000	6000	3300	3900	
	50		180	330	625	3000	6000	3400	3900	
	60	180	330	625	3000	6000	3600	3900		
	70	180	330	625	3000	6000	3800	3900		
80	180	330	625	3000	6000	4000	3900			
90	120	225	500	3000	6000	4200	3900			
100	120	225	500	3000	6000	4300	3900			

尺寸 Frame size	段位 Stage	减速比 Ratio	※8	※9	※10	重量 Weight [kg]	惯性力矩 Moment of inertia (≤Φ14) [kgcm ²]	惯性力矩 Moment of inertia (≤Φ19) [kgcm ²]	惯性力矩 Moment of inertia (≤Φ28) [kgcm ²]	惯性力矩 Moment of inertia (≤Φ38) [kgcm ²]	
			容许最大径向负荷 Maximum radial load [N]	容许最大轴向负荷 Maximum axial load [N]	惯性力矩 Moment of inertia (≤Φ14) [kgcm ²]		惯性力矩 Moment of inertia (≤Φ19) [kgcm ²]	惯性力矩 Moment of inertia (≤Φ28) [kgcm ²]	惯性力矩 Moment of inertia (≤Φ38) [kgcm ²]		
115	1段 Stage	3	4300	3900	8	-	3.3	5.3	13		
		4	4300	3900		-	2.0	4.1	12		
		5	4300	3900		-	1.6	3.6	11		
		6	4300	3900		-	1.3	3.3	11		
		7	4300	3900		-	1.1	3.2	11		
		8	4300	3900		-	1.0	3.2	11		
		9	4300	3900		-	0.98	3.0	11		
		10	4300	3900		-	0.95	3.0	11		
		2段 Stage	15	4300		3900	8.9	0.43	0.86	2.8	-
			16	4300		3900		0.48	0.92	2.9	-
	20		4300	3900	0.40	0.83		2.8	-		
	25		4300	3900	0.38	0.82		2.8	-		
	28		4300	3900	0.44	0.88		2.8	-		
	30		4300	3900	0.29	0.74		2.7	-		
	35		4300	3900	0.37	0.81		2.7	-		
	40		4300	3900	0.28	0.73		2.7	-		
	45		4300	3900	0.37	0.80		2.7	-		
	50		4300	3900	0.28	0.73		2.7	-		
	60	4300	3900	0.28	0.73	2.7	-				
	70	4300	3900	0.28	0.73	2.7	-				
80	4300	3900	0.28	0.73	2.7	-					
90	4300	3900	0.27	0.73	2.7	-					
100	4300	3900	0.27	0.73	2.7	-					

- ※ 1 输入转速为额定转速时,使用寿命为20000小时的值
- ※ 2 启动时、停止时容许的最大值
- ※ 3 发生撞击时容许的最大值(频率最高为1000次)
- ※ 4 运转过程中,额定输入转速容许的最大值
- ※ 5 在非连续运转条件下容许的最高输入转速
- ※ 6 输入转速为额定转速时,使用寿命为20000个小时的值(作用于轴中央,轴向负荷为0时)
- ※ 7 输入转速为额定转速时,使用寿命为20000个小时的值(作用于轴芯,径向负荷为0时)
- ※ 8 径向负荷容许最大值
- ※ 9 轴向负荷容许最大值
- ※ 10 因减速比和输入轴尺寸的不同而有所不同。

- ※ 1 With nominal input speed, service life is 20,000 hours
- ※ 2 The maximum torque when starting and stopping
- ※ 3 The maximum torque when it receives shock (up to 1000times)
- ※ 4 The maximum average input speed.
- ※ 5 The maximum momentary input speed.
- ※ 6 With this load and nominal input speed, service life will be 20,000 hours (Applied to the output shaft center, at axial load 0)
- ※ 7 With this load and nominal input speed, service life will be 20,000 hours (Applied to the output side bearing, at radial load 0)
- ※ 8 The maximum radial load the reducer can accept
- ※ 9 The maximum axial load the reducer can accept
- ※ 10 The weight may vary slightly model to model.

AF-140

尺寸 Frame size	段位 Stage	减速比 Ratio	※1	※2	※3	※4	※5	※6	※7	
			容许额定扭矩 Nominal output torque [Nm]	容许最大扭矩 Maximum output torque [Nm]	紧急最大扭矩 Emergency stop torque [Nm]	容许额定输入转速 Nominal input speed [rpm]	容许最高输入转速 Maximum input speed [rpm]	容许径向负荷 Permitted radial load [N]	容许轴向负荷 Permitted axial load [N]	
140	1段 Stage	3	240	470	1000	2000	4000	3200	2400	
		4	240	700	1250	2000	4000	3500	2700	
		5	360	700	1250	2000	4000	3800	3000	
		6	360	700	1250	2000	4000	4000	3300	
		7	360	700	1250	2000	4000	4200	3500	
		8	360	700	1250	2000	4000	4400	3700	
		9	240	470	1000	2000	4000	4600	3900	
		10	240	470	1000	2000	4000	4700	4100	
		2段 Stage	15	240	470	1000	2000	4000	5400	4900
			16	360	700	1250	2000	4000	5500	5000
	20		360	700	1250	2000	4000	6000	5500	
	25		360	700	1250	2000	4000	6400	6100	
	28		360	700	1250	2000	4000	6700	6400	
	30		240	470	1000	2000	4000	6800	6600	
	35		360	700	1250	2000	4000	7200	7000	
	40		360	700	1250	2000	4000	7500	7500	
	45		240	470	1000	2000	4000	7800	7900	
	50		360	700	1250	2000	4000	8100	8200	
	60	360	700	1250	2000	4000	8600	8200		
	70	360	700	1250	2000	4000	9100	8200		
80	360	700	1250	2000	4000	9100	8200			
90	240	470	1000	2000	4000	9100	8200			
100	240	470	1000	2000	4000	9100	8200			

尺寸 Frame size	段位 Stage	减速比 Ratio	※8	※9	※10	重量 Weight [kg]	惯性力矩 Moment of inertia (≤Φ19) [kgcm ²]	惯性力矩 Moment of inertia (≤Φ28) [kgcm ²]	惯性力矩 Moment of inertia (≤Φ38) [kgcm ²]	惯性力矩 Moment of inertia (≤Φ48) [kgcm ²]	
			容许最大径向负荷 Maximum radial load [N]	容许最大轴向负荷 Maximum axial load [N]	≤Φ19 [kgcm ²]		≤Φ28 [kgcm ²]	≤Φ38 [kgcm ²]	≤Φ48 [kgcm ²]		
140	1段 Stage	3	9100	8200	16	-	12	20	42		
		4	9100	8200		-	7.5	15	37		
		5	9100	8200		-	5.8	14	36		
		6	9100	8200		-	4.9	13	35		
		7	9100	8200		-	4.1	12	34		
		8	9100	8200		-	3.8	12	34		
		9	9100	8200		-	3.6	11	34		
		10	9100	8200		-	3.5	11	34		
		2段 Stage	15	9100		8200	17	1.3	3.2	11	-
			16	9100		8200		1.5	3.5	11	-
	20		9100	8200	1.2	3.1		11	-		
	25		9100	8200	1.1	3.1		11	-		
	28		9100	8200	1.4	3.3		11	-		
	30		9100	8200	0.85	2.8		10	-		
	35		9100	8200	1.1	3.1		11	-		
	40		9100	8200	0.83	2.8		10	-		
	45		9100	8200	1.1	3.0		11	-		
	50		9100	8200	0.81	2.8		10	-		
	60	9100	8200	0.81	2.8	10	-				
	70	9100	8200	0.80	2.8	10	-				
80	9100	8200	0.80	2.8	10	-					
90	9100	8200	0.80	2.8	10	-					
100	9100	8200	0.80	2.8	10	-					

- ※ 1 输入转速为额定转速时,使用寿命为20000小时的值
- ※ 2 启动时、停止时容许的最大值
- ※ 3 发生撞击时容许的最大值(频率最高为1000次)
- ※ 4 运转过程中,额定输入转速容许的最大值
- ※ 5 在非连续运转条件下容许的最高输入转速
- ※ 6 输入转速为额定转速时,使用寿命为20000个小时的值(作用于轴中央,轴向负荷为0时)
- ※ 7 输入转速为额定转速时,使用寿命为20000个小时的值(作用于轴芯,径向负荷为0时)
- ※ 8 径向负荷容许最大值
- ※ 9 轴向负荷容许最大值
- ※ 10 因减速比和输入轴尺寸的不同而有所不同。

- ※ 1 With nominal input speed, service life is 20,000 hours
- ※ 2 The maximum torque when starting and stopping
- ※ 3 The maximum torque when it receives shock (up to 1000times)
- ※ 4 The maximum average input speed.
- ※ 5 The maximum momentary input speed.
- ※ 6 With this load and nominal input speed, service life will be 20,000 hours (Applied to the output shaft center, at axial load 0)
- ※ 7 With this load and nominal input speed, service life will be 20,000 hours (Applied to the output side bearing, at radial load 0)
- ※ 8 The maximum radial load the reducer can accept
- ※ 9 The maximum axial load the reducer can accept
- ※ 10 The weight may vary slightly model to model.

AF-060 1段 1stage

输入轴内径 Input shaft bore $\leq \Phi 8$

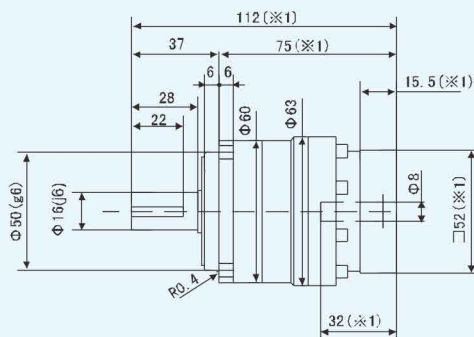
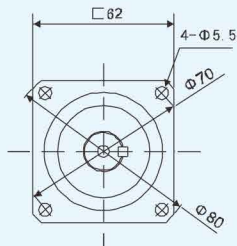

输入轴内径 Input shaft bore $\leq \Phi 14$

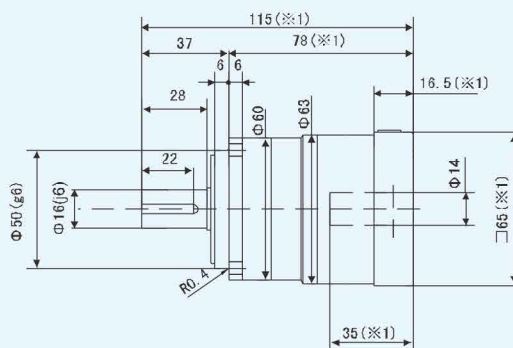
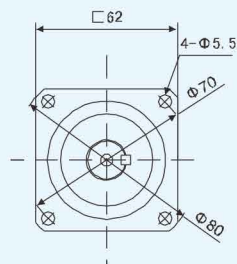

输入轴内径 Input shaft bore $\leq \Phi 19$

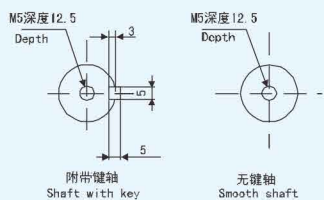
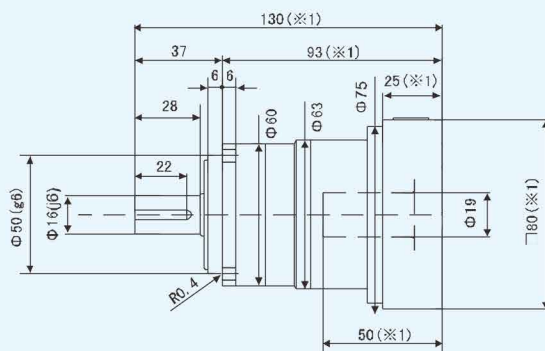
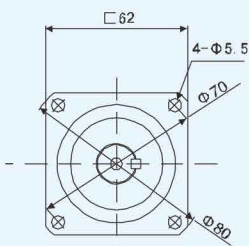

(※1) 随安装马达的不同而有所差异。

(※1) 马达轴径与输入轴径不同时，可插入轴套。

(※1) Length will vary depending motor.

(※1) Bushing will be inserted to adapt motor shaft.

AF-060 2段 2stage

输入轴内径 Input shaft bore $\leq \Phi 8$

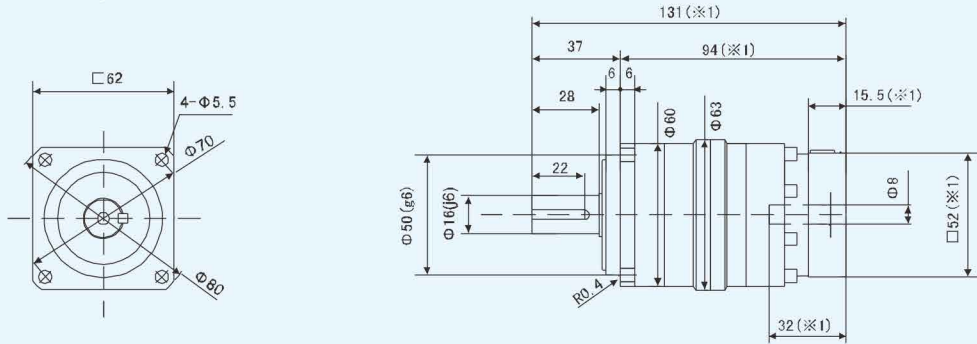

输入轴内径 Input shaft bore $\leq \Phi 14$

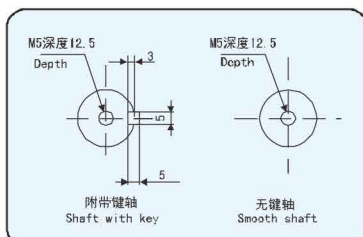
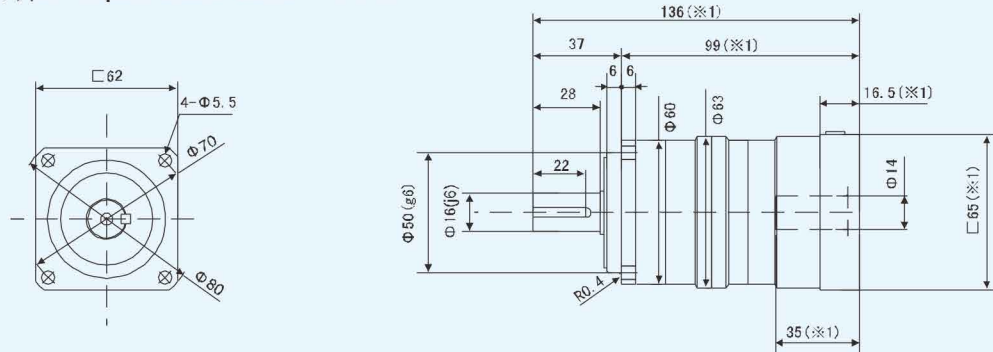

(※1) 随安装马达的不同而有所差异。

(※1) 马达轴径与输入轴径不同时，可插入轴套。

(※1) Length will vary depending motor.

(※1) Bushing will be inserted to adapt motor shaft.

AF-090 1段 1stage

输入轴内径 Input shaft bore $\leq \Phi 14$

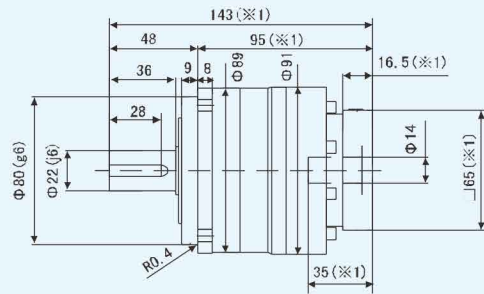
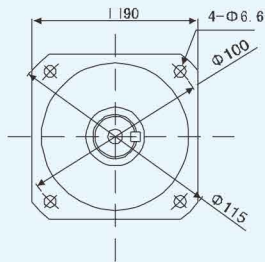

输入轴内径 Input shaft bore $\leq \Phi 19$

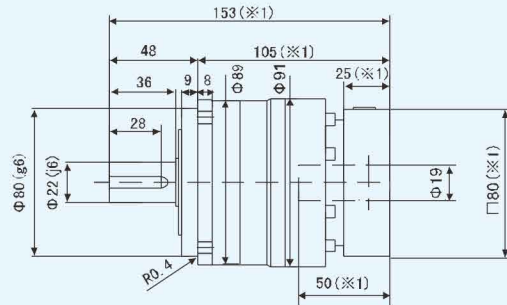
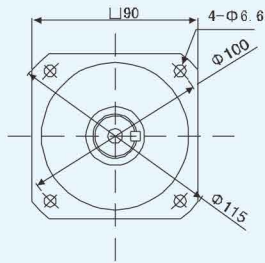

输入轴内径 Input shaft bore $\leq \Phi 28$

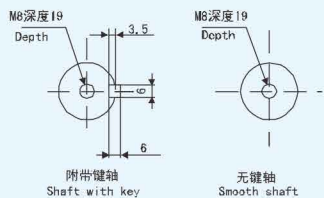
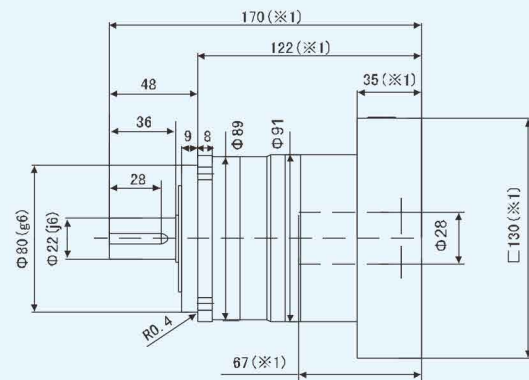
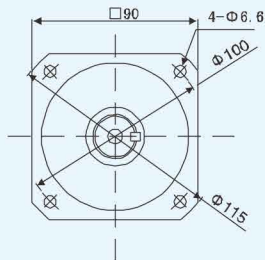

(※1) 随安装马达的不同而有所差异。

(※1) 马达轴径与输入轴径不同时，可插入轴套。

(※1) Length will vary depending motor.

(※1) Bushing will be inserted to adapt motor shaft.

AF-090 2段 2stage

输入轴内径 Input shaft bore $\leq \Phi 8$

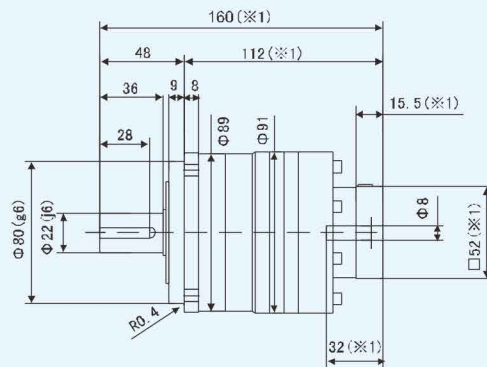
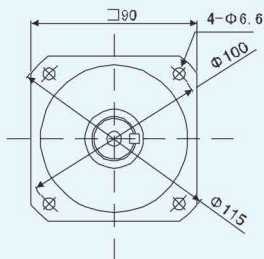

输入轴内径 Input shaft bore $\leq \Phi 14$

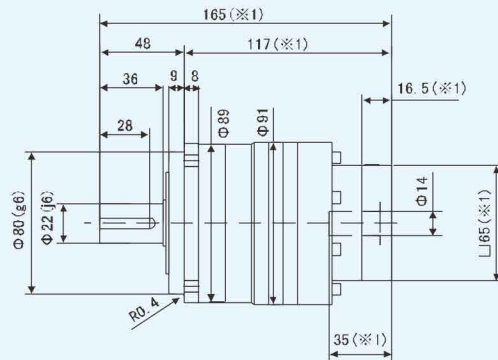
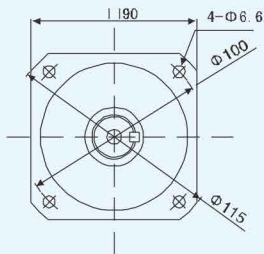

输入轴内径 Input shaft bore $\leq \Phi 19$

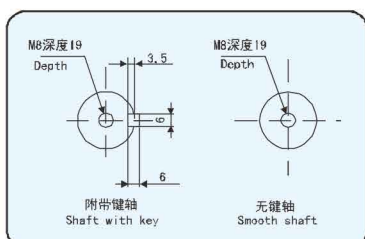
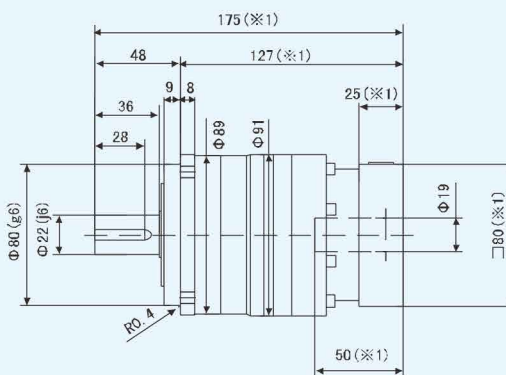
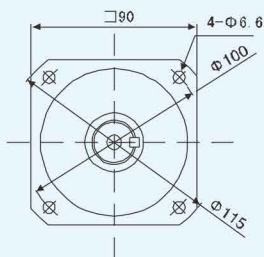

(※1) 随安装马达的不同而有所差异。

(※1) 马达轴径与输入轴径不同时，可插入轴套。

(※1) Length will vary depending motor.

(※1) Bushing will be inserted to adapt motor shaft.

AF-115 1段 1stage

输入轴内径 Input shaft bore $\leq \Phi 19$

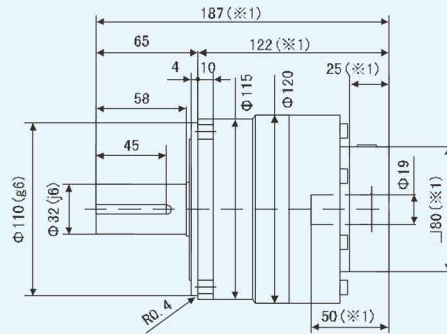
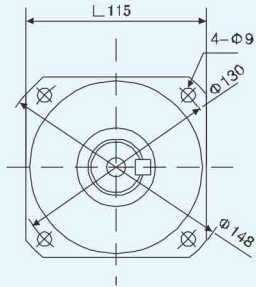

输入轴内径 Input shaft bore $\leq \Phi 28$

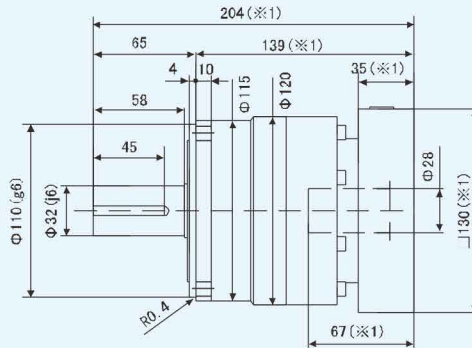
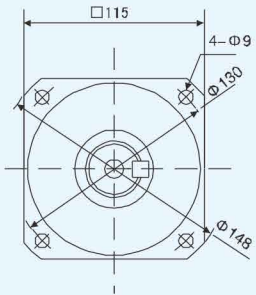

输入轴内径 Input shaft bore $\leq \Phi 38$

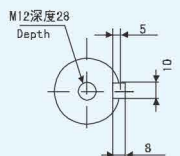
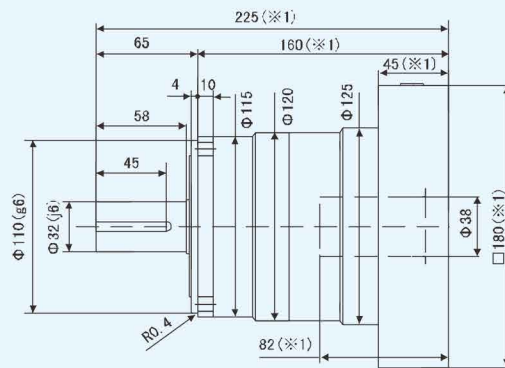
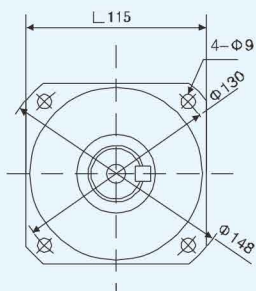

附带键轴
Shaft with key

无键轴
Smooth shaft

(※1) 随安装马达的不同而有所差异。

(※1) 马达轴径与输入轴径不同时，可插入轴套。

(※1) Length will vary depending motor.

(※1) Bushing will be inserted to adapt motor shaft.

AF-115 2段 2stage

输入轴内径 Input shaft bore $\leq \Phi 14$

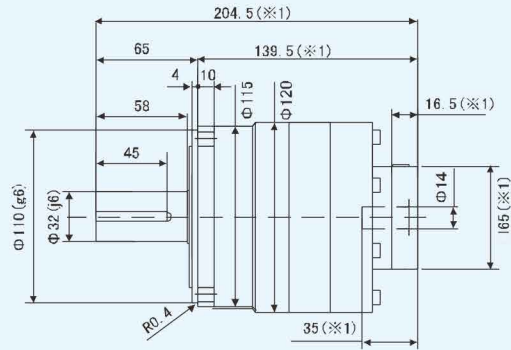
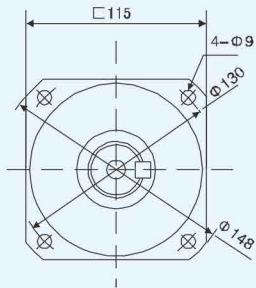

输入轴内径 Input shaft bore $\leq \Phi 19$

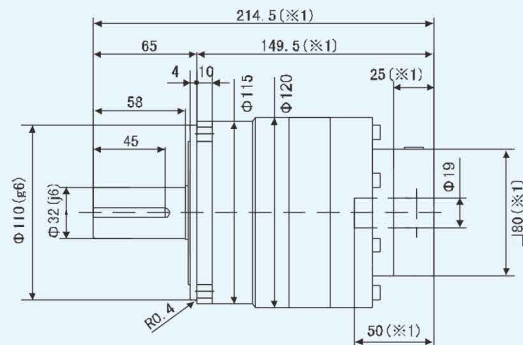
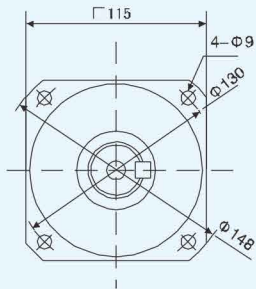

输入轴内径 Input shaft bore $\leq \Phi 28$

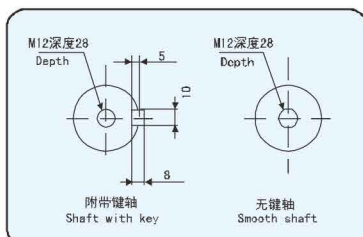
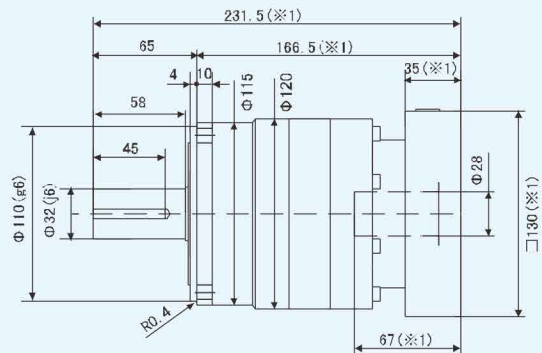
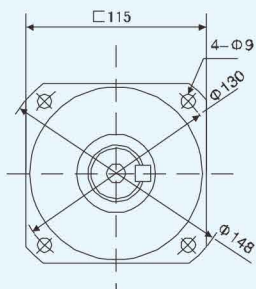

(※1) 随安装马达的不同而有所差异。

(※1) 马达轴径与输入轴径不同时，可插入轴套。

(※1) Length will vary depending motor.

(※1) Bushing will be inserted to adapt motor shaft.

AF-140 1段 1stage

输入轴内径 Input shaft bore $\leq \Phi 28$

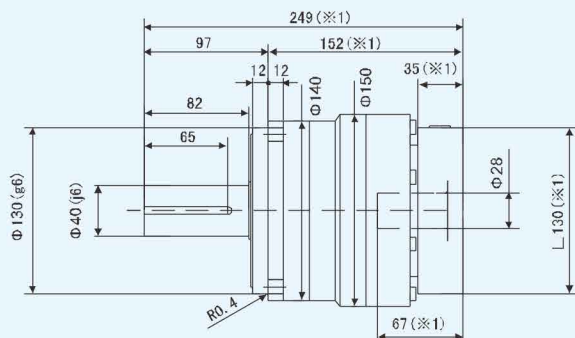
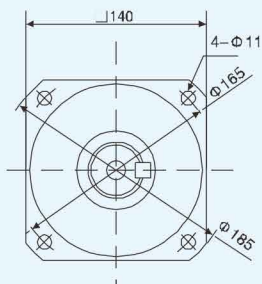

输入轴内径 Input shaft bore $\leq \Phi 38$

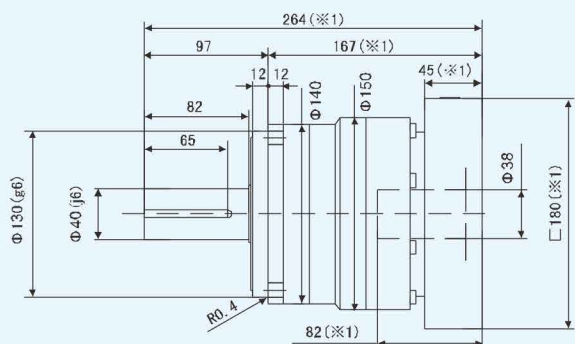
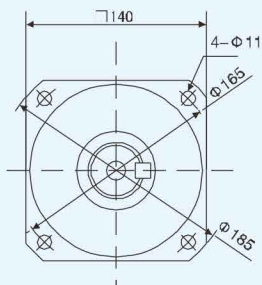

输入轴内径 Input shaft bore $\leq \Phi 48$

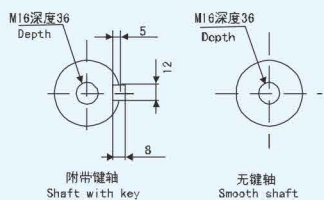
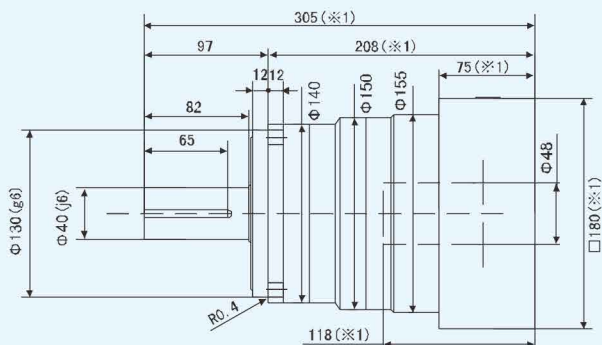
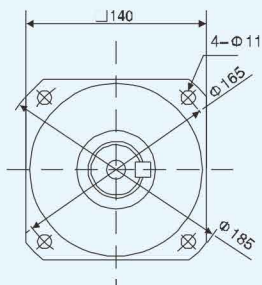

(※1) 随安装马达的不同而有所差异。

(※1) 马达轴径与输入轴径不同时，可插入轴套。

(※1) Length will vary depending motor.

(※1) Bushing will be inserted to adapt motor shaft.

AF-140 2段 2stage

输入轴内径 Input shaft bore $\leq \Phi 19$

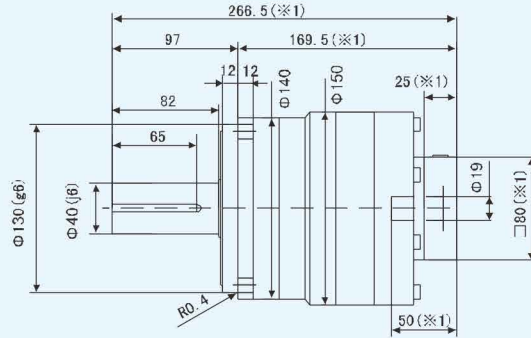
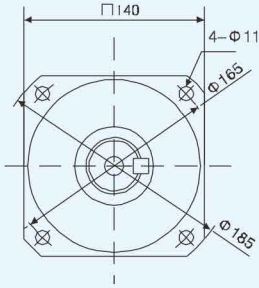

输入轴内径 Input shaft bore $\leq \Phi 28$

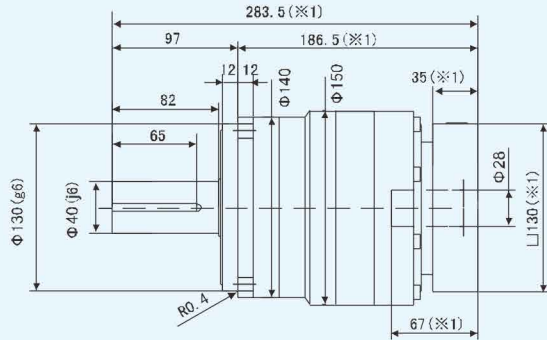
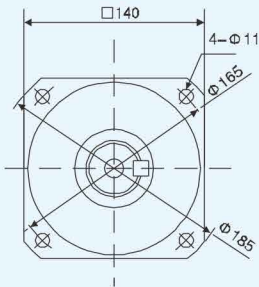

输入轴内径 Input shaft bore $\leq \Phi 38$

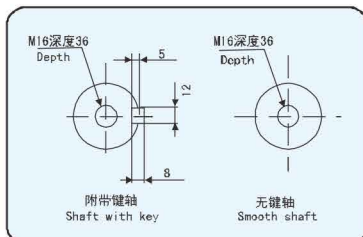
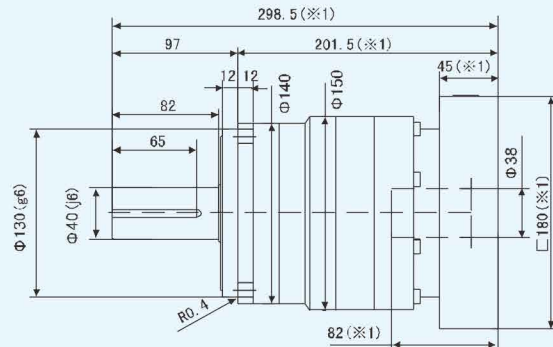
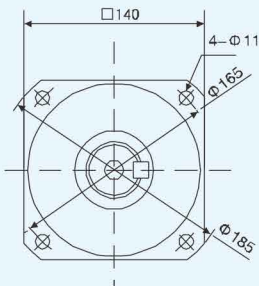

(※1) 随安装马达的不同而有所差异。

(※1) 马达轴径与输入轴径不同时，可插入轴套。

(※1) Length will vary depending motor.

(※1) Bushing will be inserted to adapt motor shaft.

AF-060

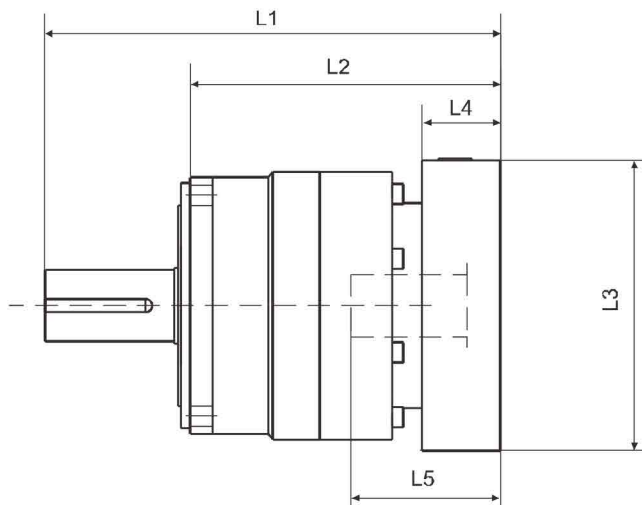

型号 Model number	**: 轴套编号 **: Adapter code	1段 Stage					2段 Stage				
		L1	L2	L3	L4	L5	L1	L2	L3	L4	L5
AF-060-□-□-8** [输入轴内径 Input shaft bore ≤ Φ8]	AA · AC · AD · AF · AG	112	75	□52	15.5	32	131	94	□52	15.5	32
	AB · AE · AH · AJ · AK	117	80	□52	20.5	37	136	99	□52	20.5	37
	BA · BB · BD · BE	112	75	□60	15.5	32	131	94	□60	15.5	32
	BC · BF	117	80	□60	20.5	37	136	99	□60	20.5	37
	CA	117	80	□70	20.5	37	136	99	□70	20.5	37
AF-060-□-□-14** [输入轴内径 Input shaft bore ≤ Φ14]	BA · BB · BD · BE · BF · BG · BJ · BK	115	78	□65	16.5	35	136	99	□65	16.5	35
	BC · BH · BM	120	83	□65	21.5	40	141	104	□65	21.5	40
	BL	125	88	□65	26.5	45	146	109	□65	26.5	45
	CA	115	78	□70	16.5	35	136	99	□70	16.5	35
	CB	120	83	□70	21.5	40	141	104	□70	21.5	40
	DA · DB · DC · DD · DF · DH	115	78	□80	16.5	35	136	99	□80	16.5	35
	DE	120	83	□80	21.5	40	141	104	□80	21.5	40
	DG	125	88	□80	26.5	45	146	109	□80	26.5	45
	EA · EB · EC	115	78	□90	16.5	35	136	99	□90	16.5	35
	ED	125	88	□90	26.5	45	146	109	□90	26.5	45
	FA	115	78	□100	16.5	35	136	99	□100	16.5	35
	GA	115	78	□115	16.5	35	136	99	□115	16.5	35
AF-060- - -19** [输入轴内径 Input shaft bore ≤ Φ19]	DA · DB · DC	130	93	□80	25	50	-	-	-	-	-
	DD	140	103	□80	35	60	-	-	-	-	-
	DE	135	98	□80	30	55	-	-	-	-	-
	EA	135	98	□90	30	55	-	-	-	-	-
	EB	130	93	□90	25	50	-	-	-	-	-
	EC	140	103	□90	35	60	-	-	-	-	-
	FA	130	93	□100	25	50	-	-	-	-	-
	FB	140	103	□100	35	60	-	-	-	-	-
	GA · GC	135	98	□115	30	55	-	-	-	-	-
	GB · GD	130	93	□115	25	50	-	-	-	-	-
	HA	130	93	□130	25	50	-	-	-	-	-
	HB	145	108	□130	40	65	-	-	-	-	-
	HC · HD · HE	135	98	□130	30	55	-	-	-	-	-

※1 1段减速: 1/3~1/10; 2段减速: 1/15~1/100
 ※2 马达轴径与输入轴径不同时, 可插入轴套

※1 1stage reduction :1/3~1/10, 2stage reduction:1/15~1/100
 ※2 Bushing will be inserted to adapt to motor shaft.

AF-090

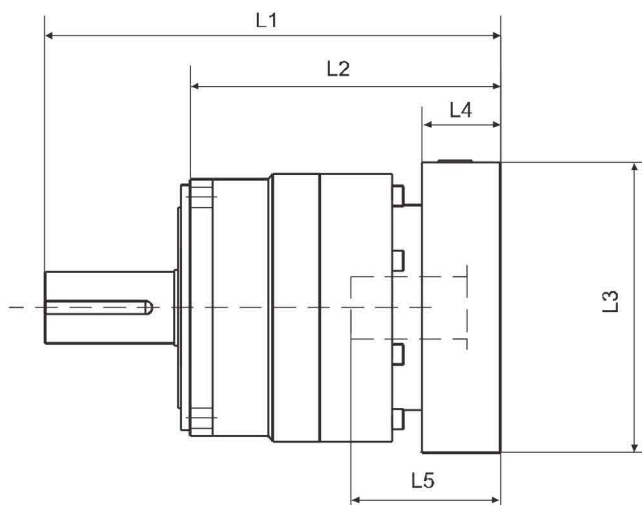

型号 Model number	**: 轴套编号 ***: Adapter code	1段 Stage					2段 Stage				
		L1	L2	L3	L4	L5	L1	L2	L3	L4	L5
AF-090-□-□-8** [输入轴内径 Input shaft bore ≅ Φ8]	AA · AC · AD · AF · AG	-	-	-	-	-	160	112	□52	15.5	32
	AB · AE · AH · AJ · AK	-	-	-	-	-	165	117	□52	20.5	37
	BA · BB · BD · BE	-	-	-	-	-	160	112	□60	15.5	32
	BC · BF	-	-	-	-	-	165	117	□60	20.5	37
	CA	-	-	-	-	-	165	117	□70	20.5	37
AF-090-□-□-14** [输入轴内径 Input shaft bore < Φ14]	BA · BB · BD · BE · BF · BG · BJ · BK	143	95	□65	16.5	35	165	117	□65	16.5	35
	BC · BH · BM	148	100	□65	21.5	40	170	122	□65	21.5	40
	BL	153	105	□65	26.5	45	175	127	□65	26.5	45
	CA	143	95	□70	16.5	35	165	117	□70	16.5	35
	CB	148	100	□70	21.5	40	170	122	□70	21.5	40
	DA · DB · DC · DD · DF · DH	143	95	□80	16.5	35	165	117	□80	16.5	35
	DE	148	100	□80	21.5	40	170	122	□80	21.5	40
	DG	153	105	□80	26.5	45	175	127	□80	26.5	45
	EA · EB · EC	143	95	□90	16.5	35	165	117	□90	16.5	35
	ED	153	105	□90	26.5	45	175	127	□90	26.5	45
	FA	143	95	□100	16.5	35	165	117	□100	16.5	35
	GA	143	95	□115	16.5	35	165	117	□115	16.5	35
	AF-090-□-□-19** [输入轴内径 Input shaft bore ≅ Φ19]	DA · DB · DC	153	105	□80	25	50	175	127	□80	25
DD		163	115	□80	35	60	185	137	□80	35	60
DE		158	110	□80	30	55	180	132	□80	30	55
EA		158	110	□90	30	55	180	132	□90	30	55
EB		153	105	□90	25	50	175	127	□90	25	50
EC		163	115	□90	35	60	185	137	□90	35	60
FA		153	105	□100	25	50	175	127	□100	25	50
FB		163	115	□100	35	60	185	137	□100	35	60
GA · GC		158	110	□115	30	55	180	132	□115	30	55
GB · GD		153	105	□115	25	50	175	127	□115	25	50
HA		153	105	□130	25	50	175	127	□130	25	50
HB		168	120	□130	40	65	190	142	□130	40	65
HC · HD · HE		158	110	□130	30	55	180	132	□130	30	55
AF-090-□-□-28** [输入轴内径 Input shaft bore ≅ Φ28]	FA · FB · FC	170	122	□100	35	67	-	-	-	-	-
	GA · GB · GC · GD · GE · GF · GG	170	122	□115	35	67	-	-	-	-	-
	HA · HC · HD	170	122	□130	35	67	-	-	-	-	-
	HB	180	132	□130	45	77	-	-	-	-	-
	JA · JB · JC	170	122	□150	35	67	-	-	-	-	-
	KA · KB	170	122	□180	35	67	-	-	-	-	-
	KD	180	132	□180	45	77	-	-	-	-	-
	LA	170	122	□200	35	67	-	-	-	-	-
MA	170	122	□220	35	67	-	-	-	-	-	

※1 1段减速: 1/3~1/10; 2段减速: 1/15~1/100
 ※2 马达轴径与输入轴径不同时, 可插入轴套

※1 1stage reduction : 1/3~1/10, 2stage reduction : 1/15~1/100
 ※2 Bushing will be inserted to adapt to motor shaft.

AF-115

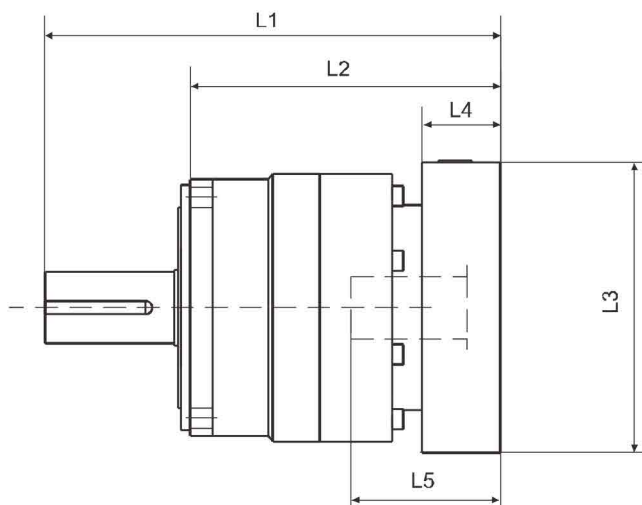

型号 Model number	**: 轴套编号 **: Adapter code	1段 Stage					2段 Stage				
		L1	L2	L3	L4	L5	L1	L2	L3	L4	L5
AF-115-□-□-14** [输入轴内径 Input shaft bore ≦ Φ14]	BA · BB · BD · BE · BF · BG · BJ · BK	-	-	-	-	-	204.5	139.5	□65	16.5	35
	BC · BH · BM	-	-	-	-	-	209.5	144.5	□65	21.5	40
	BL	-	-	-	-	-	214.5	149.5	□65	26.5	45
	CA	-	-	-	-	-	204.5	139.5	□70	16.5	35
	CB	-	-	-	-	-	209.5	144.5	□70	21.5	40
	DA · DB · DC · DD · DF · DH	-	-	-	-	-	204.5	139.5	□80	16.5	35
	DE	-	-	-	-	-	209.5	144.5	□80	21.5	40
	DG	-	-	-	-	-	214.5	149.5	□80	26.5	45
	EA · EB · EC	-	-	-	-	-	204.5	139.5	□90	16.5	35
	ED	-	-	-	-	-	214.5	149.5	□90	26.5	45
	FA	-	-	-	-	-	204.5	139.5	□100	16.5	35
GA	-	-	-	-	-	204.5	139.5	□115	16.5	35	
AF-115-□-□-19** [输入轴内径 Input shaft bore ≦ Φ19]	DA · DB · DC	187	122	□80	25	50	214.5	149.5	□80	25	50
	DD	197	132	□80	35	60	224.5	159.5	□80	35	60
	DE	192	127	□80	30	55	219.5	154.5	□80	30	55
	EA	192	127	□90	30	55	219.5	154.5	□90	30	55
	EB	187	122	□90	25	50	214.5	149.5	□90	25	50
	EC	197	132	□90	35	60	224.5	159.5	□90	35	60
	FA	187	122	□100	25	50	214.5	149.5	□100	25	50
	FB	197	132	□100	35	60	224.5	159.5	□100	35	60
	GA · GC	192	127	□115	30	55	219.5	154.5	□115	30	55
	GB · GD	187	122	□115	25	50	214.5	149.5	□115	25	50
	HA	187	122	□130	25	50	214.5	149.5	□130	25	50
	HB	202	137	□130	40	65	229.5	164.5	□130	40	65
	HC · HD · HE	192	127	□130	30	55	219.5	154.5	□130	30	55
AF-115-□-□-28** [输入轴内径 Input shaft bore ≦ Φ28]	FA · FB · FC	204	139	□100	35	67	231.5	166.5	□100	35	67
	GA · GB · GC · GD · GE · GF · GG	204	139	□115	35	67	231.5	166.5	□115	35	67
	HA · HC · HD	204	139	□130	35	67	231.5	166.5	□130	35	67
	HB	214	149	□130	45	77	241.5	175.5	□130	45	77
	JA · JB · JC	204	139	□150	35	67	231.5	166.5	□150	35	67
	KA · KB	204	139	□180	35	67	231.5	166.5	□180	35	67
	KD	214	149	□180	45	77	241.5	176.5	□180	45	77
	LA	204	139	□200	35	67	231.5	166.5	□200	35	67
	MA	204	139	□220	35	67	231.5	166.5	□220	35	67
AF-115-□-□-38** [输入轴内径 Input shaft bore ≦ Φ38]	HA	225	160	□130	45	82	-	-	-	-	-
	HB	220	155	□130	40	77	-	-	-	-	-
	JA	225	160	□150	45	82	-	-	-	-	-
	KA · KB · KC	225	160	□180	45	82	-	-	-	-	-
	LA	225	160	□200	45	82	-	-	-	-	-
	LB	235	170	□200	55	92	-	-	-	-	-
	MA · MB	225	160	□220	45	82	-	-	-	-	-
	NA	225	160	□250	45	82	-	-	-	-	-

※1 1段减速: 1/3~1/10; 2段减速: 1/15~1/100
 ※2 马达轴径与输入轴径不同时, 可插入轴套

※1 1stage reduction : 1/3~1/10, 2stage reduction : 1/15~1/100
 ※2 Bushing will be inserted to adapt to motor shaft.

AF-140

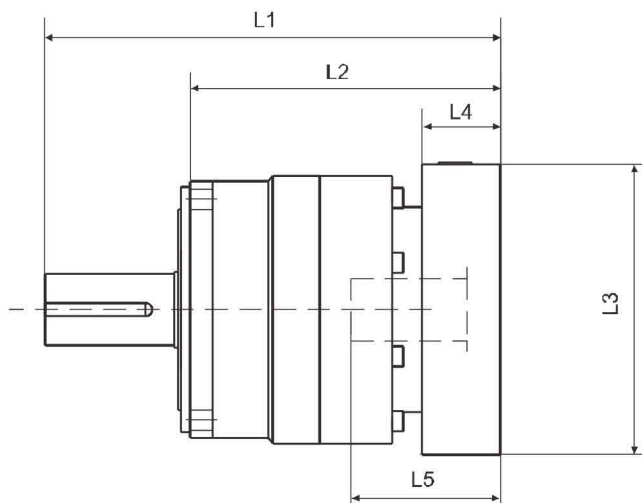

型号 Model number	**: 轴套编号 **: Adapter code	1段 Stage					2段 Stage				
		L1	L2	L3	L4	L5	L1	L2	L3	L4	L5
AF-140-□-□-19** [输入轴内径 Input shaft bore ≤ Φ19]	DA · DB · DC	-	-	-	-	-	266.5	169.5	□80	25	50
	DD	-	-	-	-	-	276.5	179.5	□80	35	60
	DE	-	-	-	-	-	271.5	174.5	□80	30	55
	EA	-	-	-	-	-	271.5	174.5	□90	30	55
	EB	-	-	-	-	-	266.5	169.5	□90	25	50
	EC	-	-	-	-	-	276.5	179.5	□90	35	60
	FA	-	-	-	-	-	266.5	169.5	□100	25	50
	FB	-	-	-	-	-	276.5	179.5	□100	35	60
	GA · GC	-	-	-	-	-	271.5	174.5	□115	30	55
	GB · GD	-	-	-	-	-	266.5	169.5	□115	25	50
	HA	-	-	-	-	-	266.5	169.5	□130	25	50
	HB	-	-	-	-	-	281.5	184.5	□130	40	65
	HC · HD · HE	-	-	-	-	-	271.5	174.5	□130	30	55
	AF-140-L-□-28** [输入轴内径 Input shaft bore ≤ Φ28]	FA · FB · FC	249	152	□100	35	67	283.5	186.5	□100	35
GA · GB · GC · GD · GE · GF · GG		249	152	□115	35	67	283.5	186.5	□115	35	67
HA · HC · HD		249	152	□130	35	67	283.5	186.5	□130	35	67
HB		259	162	□130	45	77	293.5	196.5	□130	45	77
JA · JB · JC		249	152	□150	35	67	283.5	186.5	□150	35	67
KA · KB		249	152	□180	35	67	283.5	186.5	□180	35	67
KD		259	162	□180	45	77	293.5	196.5	□180	45	77
LA		249	152	□200	35	67	283.5	186.5	□200	35	67
MA		249	152	□220	35	67	283.5	186.5	□220	35	67
AF-140-□-□-38** [输入轴内径 Input shaft bore ≤ Φ38]		HA	264	167	□130	45	82	298.5	201.5	□130	45
	HB	259	162	□130	40	77	293.5	196.5	□130	40	77
	JA	264	167	□150	45	82	298.5	201.5	□150	45	82
	KA · KB · KC	264	167	□180	45	82	298.5	201.5	□180	45	82
	LA	264	167	□200	45	82	298.5	201.5	□200	45	82
	LB	274	177	□200	55	92	308.5	211.5	□200	55	92
	MA · MB	264	167	□220	45	82	298.5	201.5	□220	45	82
	NA	264	167	□250	45	82	298.5	201.5	□250	45	82
AF-140-□-□-48** [输入轴内径 Input shaft bore ≤ Φ48]	KB · KC	285	188	□180	55	98	-	-	-	-	-
	KA	305	208	□180	75	118	-	-	-	-	-
	LA	285	188	□200	55	98	-	-	-	-	-
	MA	285	188	□220	55	98	-	-	-	-	-
	MB	305	208	□220	75	118	-	-	-	-	-
	NA	305	208	□250	75	118	-	-	-	-	-
	PA	305	208	□280	75	118	-	-	-	-	-

※1 1段减速: 1/3~1/10; 2段减速: 1/15~1/100
 ※2 马达轴径与输入轴径不同时, 可插入轴套

※1 1stage reduction : 1/3~1/10, 2stage reduction : 1/15~1/100
 ※2 Bushing will be inserted to adapt to motor shaft.