

# Precision Planetary Gearbox

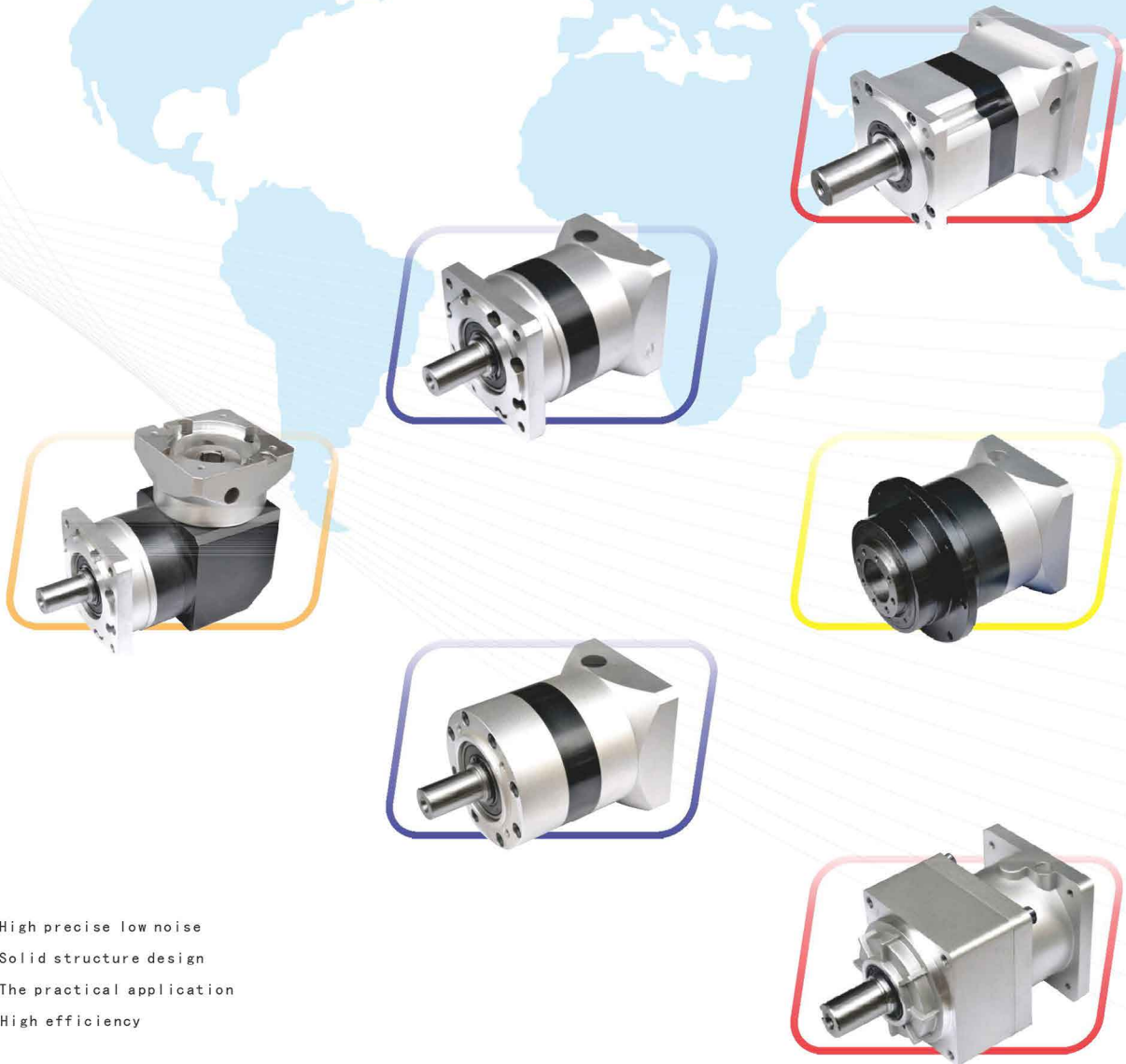

High precise low noise  
Solid structure design  
The practical application  
High efficiency

伍勒斯精密机械有限公司  
**WOOLARS PRECISION MACHINERY CO., LIMITED**

2018版  
Product catalogue  
welcome to consult for more information

## 一、Product introduction

- 1、The box enclosure is hexagonal shape, five of which surface mounting holes
- 2、90 degrees, reversing design service life is long, large carrying capacity, smooth transmission, low noise, the reversing transmission efficiency is more than 95%
- 3、Arc tooth taper gear set is made of high quality low carbon alloy steel, after carburizing, quenching, grinding the running-in, the realization of high precision hard tooth face closed transmission
- 4、ZPT series have four kinds of specifications, a variety of speed ratio, large range of selection and output in a variety of forms, can meet the needs of a variety of occasions
- 5、Slowing, growth in two types of transmission can be realized

## 二、Model specification

- Reducer specifications  → According to the product series ( See the table below )
- series  → Reducer stage
- Reduction ratio  → According to the product series ( See the table below )
- Output shaft way  → S2:With the ordinary flat key standard;S1:Optical axis; K:Single bond hole hollow
- The degree of precision  → P2:The standard back lash(Don't indicate as default)  
P1:Precision back lash  
P0:Ultra-precision back lash
- Special customized  → No special custom, no logo

type	Rated /maximum output torque	ratio(Only when reversing)	ratio 1 stage(L1)	ratio 2 stage(L2)	ratio 3 stage(L3)
ZPT075	35Nm/70Nm	2	6、8、10、14、20	32、40、50、56、70 80、100、140	128、160、200、224、250、280、 320、350、400、500、560、700
ZSPT075					
ZPT090	45Nm/90Nm	1	3、4、5、7、10	12、16、20、25、28、 35、40、50	80、100、125、140、175、200、250
ZSPT090					
ZPT110	80Nm/160Nm	1	3、4、5、7、10	12、16、20、25、28、 35、40、50	80、100、125、140、175、200、250
ZSPT110					
ZPT140	170Nm/340Nm	1	3、4、5、7、10	12、16、20、25、28、 35、40、50	80、100、125、140、175、200、250
ZSPT140					
Full efficiency		98%	94%	91%	88%

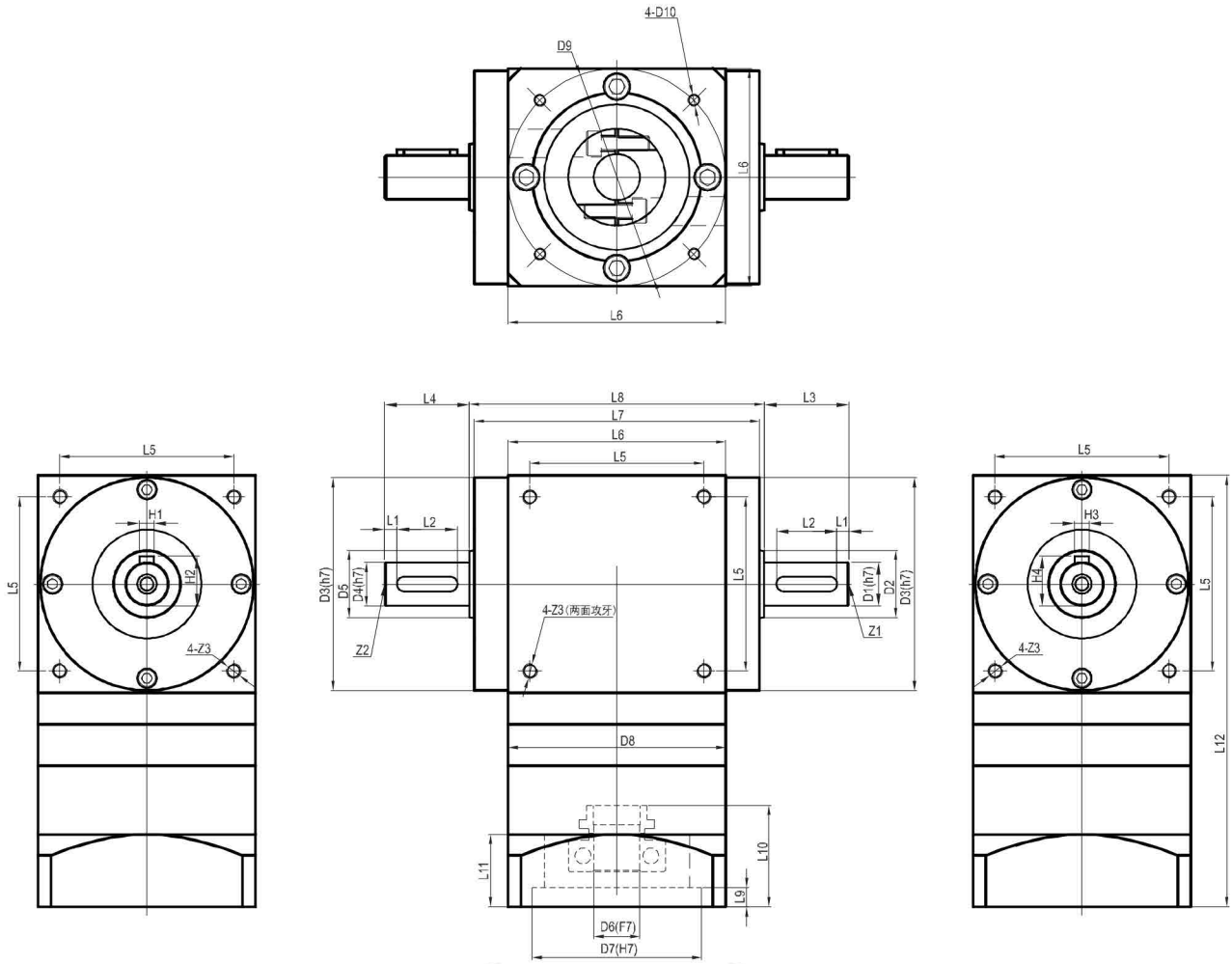

Unit:mm

type \ size	D1	D2	D3	D4	D5	D6	D7	D8	D9	D10	L1	L2	L3	L4	L5	L6	L7	L8
ZPT075	14.0	22.0	73.0	14.0	22.0	14.0	50.0	70.0	70.0	M4	2.0	25.0	28.5	28.5	60.0	75.0	104.0	108.0
ZPT090	18.0	28.0	88.0	18.0	28.0	19.0	70.0	90.0	90.0	M5	5.0	25.0	35.0	35.0	72.0	90.0	118.0	122.0
ZPT110	22.0	35.0	108.0	22.0	35.0	19.0	70.0	90.0	90.0	M5	3.0	30.0	35.0	35.0	88.0	110.0	134.0	138.0
ZPT140	32.0	45.0	135.0	32.0	45.0	22.0	110.0	120.0	145.0	M8	5.0	40.0	50.0	50.0	110.0	140.0	170.0	174.0

type \ size	L9	L10	L11	L12		H1	H2	H3	H4	Z1	Z2	Z3					
				reversing	1 stage												
ZPT075	5.0	31.0	22.0	indeterminate	144.5	161.0	5.0	16.0	5.0	16.0	M5	M5	M6				
ZPT090	8.0	42.0	30.0	indeterminate	178.5	202.5	6.0	20.5	6.0	20.5	M6	M6	M6				
ZPT110	8.0	42.0	30.0	indeterminate	200.0	224.0	6.0	24.5	6.0	24.5	M8	M8	M8				
ZPT140	8.0	59.0	44.0	indeterminate	269.5	301.0	10.0	35.0	10.0	35.0	M10	M10	M10				

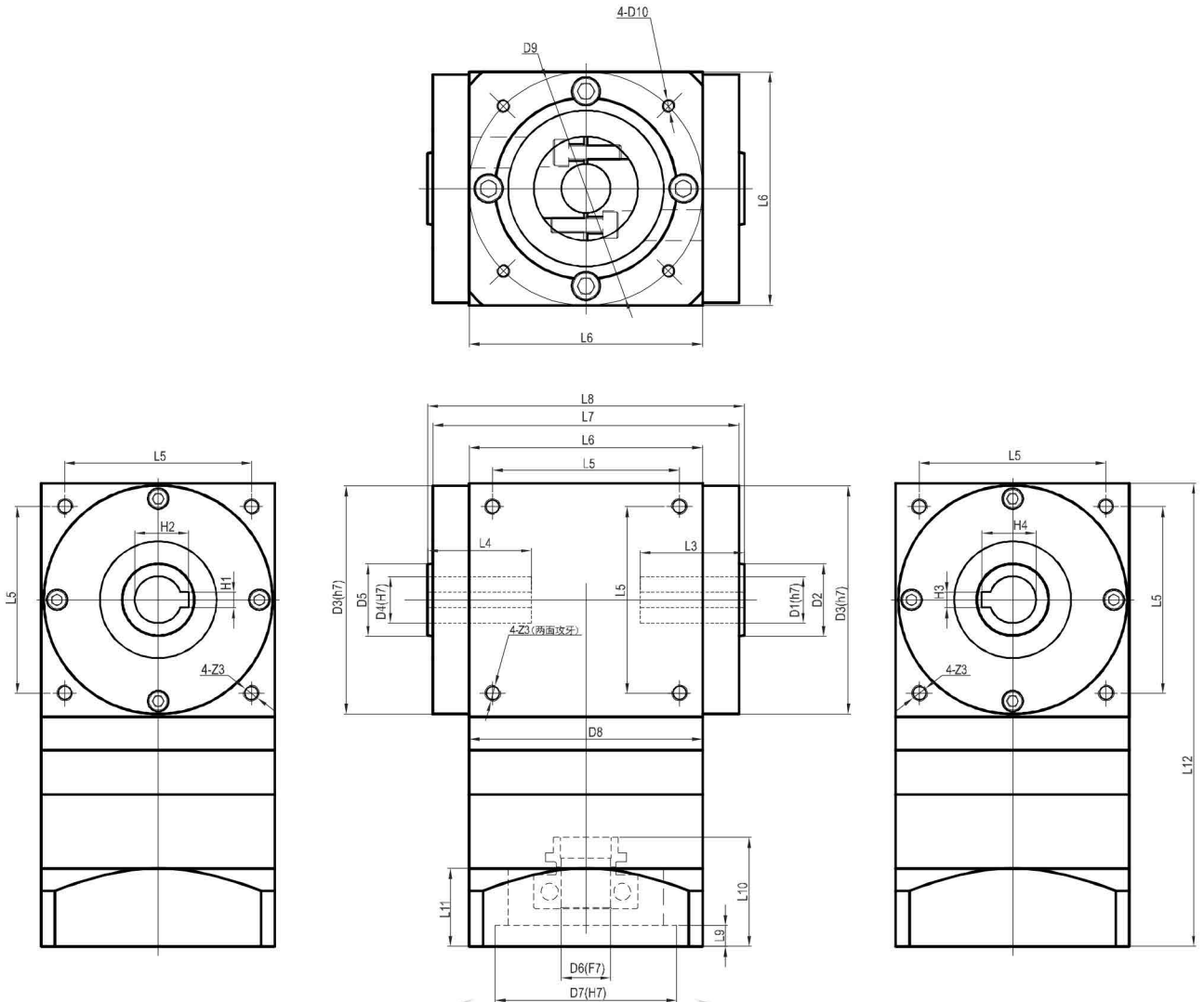

View mode

Unit:mm

size	D1	D2	D3	D4	D5	D6	D7	D8	D9	D10	L1	L2	L3	L4	L5	L6	L7	L8
ZPT075	14.0	22.0	73.0	14.0	22.0	14.0	50.0	70.0	70.0	M4	\	\	30.0	30.0	60.0	75.0	104.0	108.0
ZPT090	18.0	28.0	88.0	18.0	28.0	19.0	70.0	90.0	90.0	M5	\	\	40.0	40.0	72.0	90.0	118.0	122.0
ZPT110	22.0	35.0	108.0	22.0	35.0	19.0	70.0	90.0	90.0	M5	\	\	45.0	45.0	88.0	110.0	134.0	138.0
ZPT140	28.0	45.0	135.0	28.0	45.0	22.0	110.0	120.0	145.0	M8	\	\	45.0	45.0	110.0	140.0	170.0	174.0

size	L9	L10	L11	L12		H1	H2	H3	H4	Z1	Z2	Z3				
type				reversing	1 stage	2 stage										
ZPT075	5.0	31.0	22.0	indeterminate	144.5	161.0	5.0	16.3	5.0	16.3	\	\	M6			
ZPT090	8.0	42.0	30.0	indeterminate	178.5	202.5	6.0	20.8	6.0	20.8	\	\	M6			
ZPT110	8.0	42.0	30.0	indeterminate	200.0	224.0	6.0	24.8	6.0	24.8	\	\	M8			
ZPT140	8.0	59.0	44.0	indeterminate	269.5	301.0	8.0	31.3	8.0	31.3	\	\	M10			

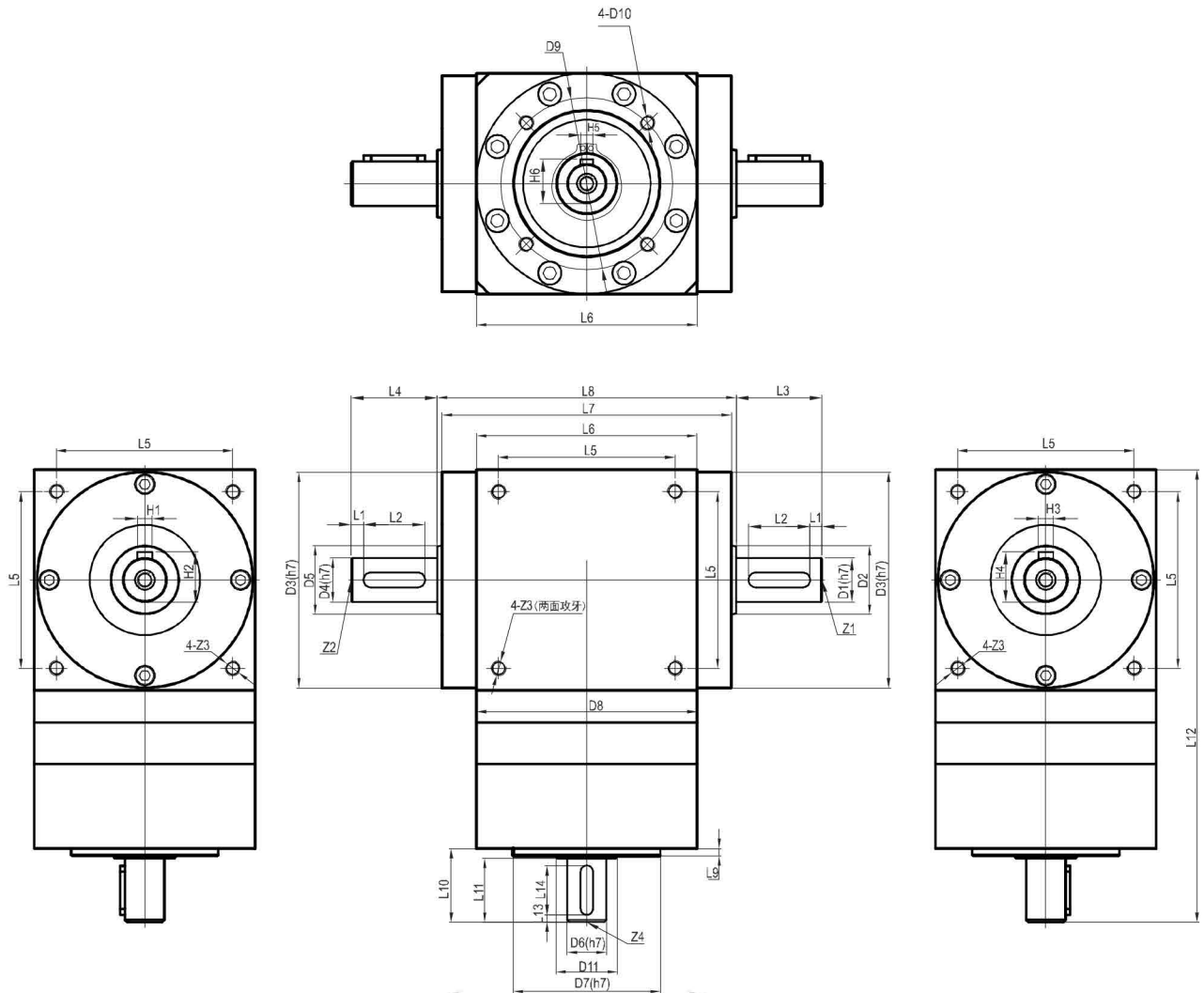

View mode

Unit:mm

type \ size	D1	D2	D3	D4	D5	D6	D7	D8	D9	D10	D11	L1	L2	L3	L4	L5	L6	L7	L8
ZSPT075	14.0	22.0	73.0	14.0	22.0	10.0	40.0	70.0	52.0	M5	17.0	2.0	25.0	28.5	28.5	60.0	75.0	104.0	108.0
ZSPT090	18.0	28.0	88.0	18.0	28.0	16.0	60.0	90.0	70.0	M6	25.0	5.0	25.0	35.0	35.0	72.0	90.0	118.0	122.0
ZSPT110	22.0	35.0	108.0	22.0	35.0	16.0	60.0	90.0	70.0	M6	25.0	3.0	30.0	35.0	35.0	88.0	110.0	134.0	138.0
ZSPT140	32.0	45.0	135.0	32.0	45.0	20.0	80.0	120.0	100.0	M10	35.0	5.0	40.0	50.0	50.0	110.0	140.0	170.0	174.0

type \ size	L9	L10	L11	L12		L13	L14	H1	H2	H3	H4	H5	H6	Z1	Z2	Z3	Z4	
				reversing	1 stage													2 stage
ZSPT075	3.0	25.0	21.0	indeterminate	153.0	169.5	3.0	15.0	5.0	16.0	5.0	16.0	3.0	11.2	M5	M5	M6	M3
ZSPT090	3.0	30.0	26.0	indeterminate	189.5	213.5	3.0	20.0	6.0	20.5	6.0	20.5	5.0	18.0	M6	M6	M6	M5
ZSPT110	3.0	30.0	26.0	indeterminate	235.0	259.0	3.0	20.0	6.0	24.5	6.0	24.5	5.0	18.0	M8	M8	M8	M5
ZSPT140	4.0	46.0	40.0	indeterminate	286.5	318.0	5.0	30.0	10.0	35.0	10.0	35.0	6.0	22.5	M10	M10	M10	M6

